

Revised 05/20/09

TECHNICAL INNOVATIONS
1271 LaQuinta Drive #6
Orlando, FL 32809
407-601-1975

Assembly Instructions for HOME-DOME™ Observatory
HD6

S/N _____

Congratulations.

You have purchased a HOME-DOME® observatory, which will serve you well in the years to come. We are sure your new dome will increase your enjoyment of observing, and help you be a more active astronomer.

Even though you will be constructing the equivalent of a small building, the HOME-DOME is easy to assemble. However, it is essential that you read these instructions because the assembly involves the handling of fairly large structural pieces, use of power tools, and the need to perform mechanical assembly. Assembly should be an enjoyable experience, so take your time and be careful.

We hope and believe that you will be happy with this product. We ask that you let us know of any suggestions or criticisms of our products. We have incorporated many ideas from customers into these instructions, and into the HOME-DOME design. We thank all who contributed (and you are the beneficiary!) If, at any time, you have questions, please feel free to give us a call so we can help you. Our aim is for you to be satisfied!

Jerry W. Smith
Technical Innovations

CAUTION

Handling fiberglass improperly can result in skin injury, while failure to perform several easy, but crucial, steps in the HOME-DOME assembly can cause the HOME-DOME not to operate properly. In addition, failure to follow recommended assembly may result in injury during or after construction. Please at least scan all parts of these instructions, even those parts covering skills you already have.

Technical Innovations is not responsible and assumes no liability for any damage or injury arising from assembly or use of this product. While the instructions include cautions and warnings, it is ultimately the customer who must exercise good judgment and care in the assembly and while the observatory is in use to avoid damage to materials or persons, and it is the customer who assumes all risk and liability.

NOTICE

All portions of this instruction manual are copyrighted by Technical Innovations, 1998, and are protected under the laws of the United States. This document may not be reproduced without the consent of Technical Innovations except for use by the purchaser during assembly.

This observatory is patented, US Patent 5,448,860.

TABLE OF CONTENTS

PARTS LIST HD6	5
STAINLESS STEEL BOLT COUNT FOR HD6	8
1. Introduction to Instructions	9
Foundation.....	9
Foundation bolts	9
Installation Practices	10
2. Safety Precautions	11
Fiberglass	11
Construction and Operation Cautions.....	12
3. Special Assembly Instructions	13
Nomenclature	13
Locating Holes	13
Drilling and Bolting	14
Leveling the Foundation and Base Ring.....	15
Leveling with Carpenter Level	15
Leveling with Water Level.....	16
Making the Observatory Circular, and maybe Centered.....	16
Stainless Steel Cable	17
4. HD6 Base Ring Construction.....	18
Overview	18
Base Ring Preparation and Assembly.....	19
Roller Mounting	20
Support Rollers.....	20
Side Rollers	21
Splice Plate Installation	22
5. Shutters, Rear Cover, DSR Preparation	24
Front Shutter Preparation	24
Security and Locks	25
Top Shutter Preparation and Latches	26
Top Shutter Restraint System J-Guides.....	26
Rear Cover Preparation	26
Electric Shutter.....	27
Shutter Catchers	27
Dome Support Ring (DSR)	27
6. Dome Construction	29
Overview of the Action	29
Dome Assembly (Note that both halves of the dome are identical).....	29
Rear Cover	30
Dome Inspection and Final Bolting.....	31
Shutter Installation and Initial Operation	32
Protect Your Dome	33
8. Finish Work	34
Shutter Restraint System	34
Anti Rotation Bolts.....	36

Caulking	36
Instruction Sheet.....	37
9. Problem Solving.....	38
Dome Rotation Problems	38
Shutter Engagement Problems.....	39
Shutter Dis-engagement Problems	39
Shutter Blow-off.....	40
Base Ring Service	41
9. Use and Care of your HOME-DOME.....	42

APPENDICES

Hole Drilling Guide
 Figures 1-24
 Shutter Pole Design
 Specifications
 Terms, Warranties,
 Disclosures
 Instruction Sheet

**INSTRUCTIONS FOR OPTIONAL
 ITEMS**

Electric Shutter
 Electric Dome Drive
 Power Supply
 Rectangular Skirt

PARTS LIST HD6

FIBERGLASS PIECES

Fiberglass Pieces

- Dome Section (2)
- Dome Support Ring Sections (2)
- Rear Cover (1)
- Top Shutter (1)
- Front Shutter (1)
- Base Ring Sections (3) for HD6S

Fittings and hardware

- Stainless Steel Flat Head Bolts
- Stainless Steel Carriage Bolts
- Nuts, washers
- Wheels and Hardware (9)
- Side Rollers and bolts (9)
- Splice plate and hardware
- Front Shutter Latch (21 in. long)
- Rear Shutter Latch (16 in. long)
- Handles (2)
- Shutter bearing strips (2 pair)
- Shutter Catcher/Wind Restraint Brackets (2)
- Shutter restraint hardware
- Fiberglass Cleaner
- Front Shutter Edge Molding
- Shutter lynch pins (2)
- Caulk
- Instructions

TOOLS AND HARDWARE TO BE PROVIDED BY INSTALLER, NOT INCLUDED WITH HD6

3/8 in electric drill with set of bits
(2 drills are even more efficient)
Countersink (82 deg. preferred)
File or rasp
Metal rule (25 ft.)
Carpenter level or water level
Hand tools: clamps, screw drivers, socket wrench set, etc.
Large metal square & straight edge
Duct tape
Caulking gun
Gloves, eye protection
Work table (e.g. sawhorses & plywood)
Extension cord(s)
Step ladder
Foundation bolts and fender washers
Thin shims and spacers for leveling **
Several lengths of 2 x 4s and 2 x 2s

** Shims – have several thicknesses available (such as 1/8", 1/4"). The design shown below is useful because you can slide it in under the fiberglass and around a bolt without having to remove everything.

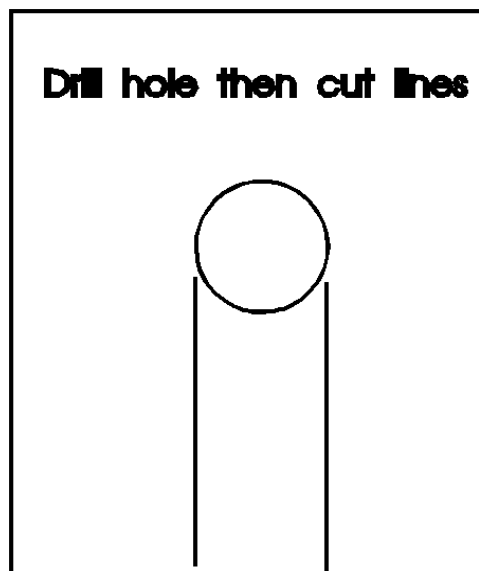

TYPICAL HD6 ASSEMBLY PROCESS

05/21/09

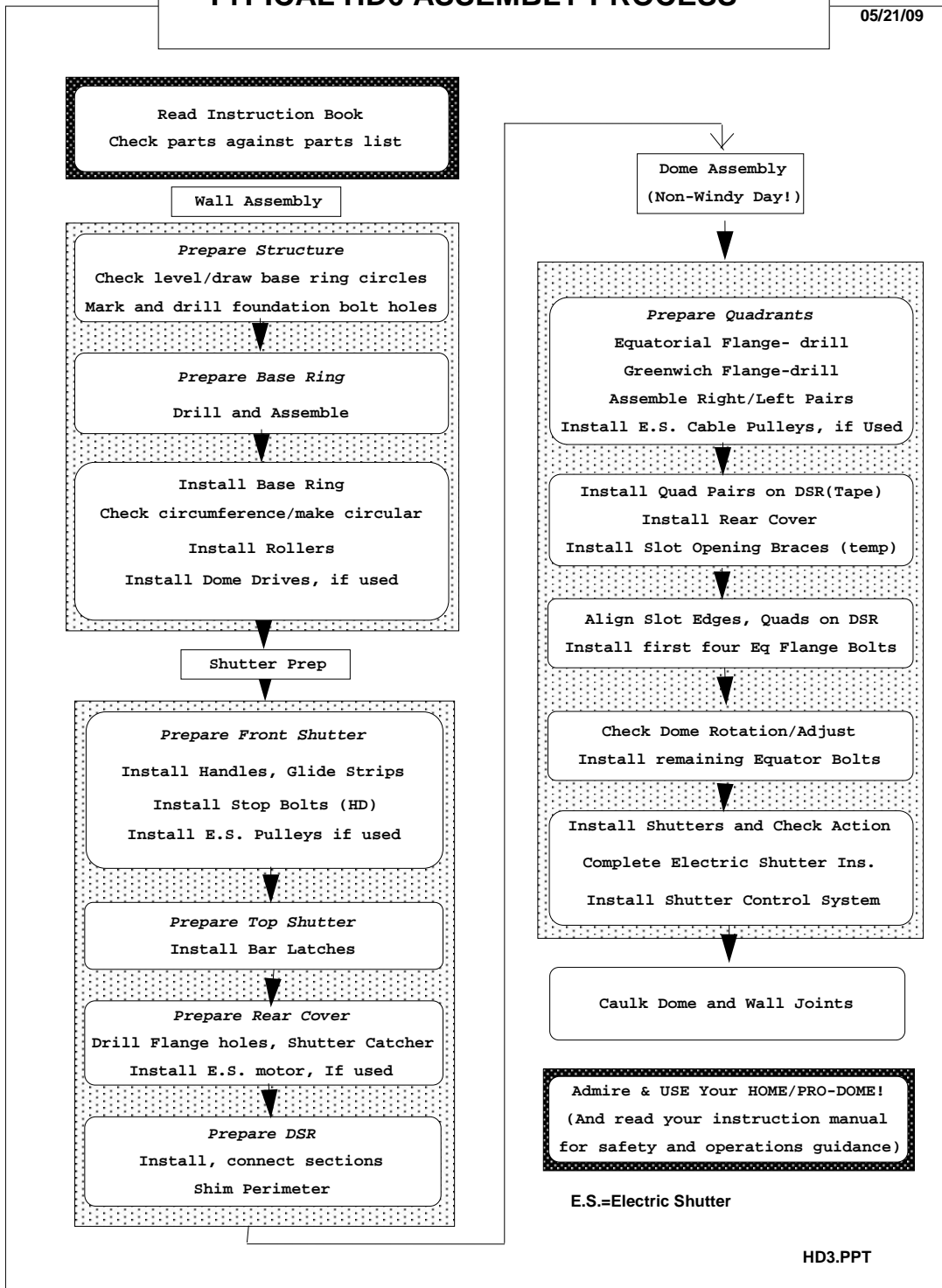

E.S.=Electric Shutter

HD3.PPT

STAINLESS STEEL BOLT COUNT FOR HD6

HD6

BOLT LOCATION	2.25" FH	1.5" FH	1"CB	3/4" FH	3/4" CB	NUTS	WASHERS
1/4-20 bolts							
BASE RING			6			6	6
D.S.R.							
DOVE- EQ. FLANGE				12		12	12
REAR COVER		10				10	10
FRONT/REAR LATCH					8	8	8
SHUTTER CATCHERS			4			4	4
HANDLES			2			2	2
WHEELS	9					9	
SHUT. STOP BOLTS			2			2	2
TOTALS	9	10	14	12	8	53	44

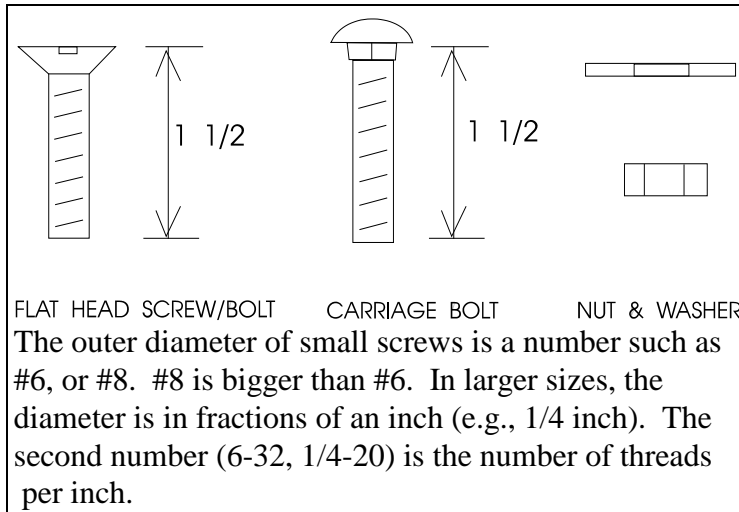

1. Introduction to Instructions

The assembly of the HOME-DOME involves several steps. These include:

- obtaining necessary permits
- building or preparing the support structure
- installing the base ring and rollers
- assuring that the top of the base ring is level and round
- preparing shutters and rear cover
- assembling the dome on the dome support ring
- installing the shutters
- installing the fittings and hardware

In some areas, building permits are needed for the installation of the HOME-DOME, although there are sometimes exemptions for structures the size of the HD6. If a permit is required, you will need to apply for it, and include sketches of the proposed location and installation. If the HOME-DOME is to be installed in or on your house or other inhabited building, special fire or other codes may apply in addition to structural integrity requirements. Check with the local officials: it is much easier to handle the questions before you build, than to find out later you are in violation of the local law.

Foundation

FIG 4,5,6

The HOME-DOME must rest on a secure framing support when installed on a structure. The major purpose of the framing is not to support the weight, since the 6 foot HOME-DOME only weighs about 110 pounds. Rather, its purpose is to provide stable support under all environmental conditions. In addition, in most cases, the foundation system must provide some means of leveling the observatory.

The mounting foundation must hold the HOME-DOME down in the case of severe wind. Depending on the area of the country, hurricane or other winds 80 mph (or more!) can occur, so building codes require that buildings and their foundations resist such winds. (An 80 mph wind on the 10 foot HOME-DOME can generate a force of over 1000 lb.!)

The foundation may be part of a building or house, a ring foundation, piers into the ground., If you want suggestions, please contact us for more information on constructing foundations.

Foundation bolts

Selecting the appropriate foundation bolts to hold the bottom ring to your surface is your responsibility. The most common bolts are lag bolts into a solid support structure, or carriage bolts through a wood support beam. In all cases, it is absolutely necessary to use

washers at least 1 1/2 inch diameter under the bolt heads. In general, we recommend using 3/8 inch diameter bolts spaced about 16-18 inches apart along the bottom flange. Lag bolts should penetrate at least two inches. Be sure to allow enough length in case you need to use shims under the wall or base. [*Bolt Hole Drilling Guide #4*]

Installation Practices

Many of the installation steps take longer to read than to do. While no complex carpentry or other skills are needed, you will need to perform some measurements, check that pieces are level and straight, locate and drill holes, and install bolts. Sometimes edges of fiberglass may need to be sanded or trimmed. However, no experience is needed in working with fiberglass, and no application of fiberglass or resin needs to be done. None of the pieces weighs more than about 45 pounds, so even though they are bulky, they are relatively easy to handle.

We would strongly urge that you have a second person helping you. This allows you to check on each other, and will help avoid mistakes. The second person can help a great deal in holding items in place while the first drills holes and installs bolts. And finally, working together makes the job more fun!

Before beginning construction, both you and your assembly partner should read through the directions and study the pictures. Note especially the terminology that we use for the various parts. We urge that you not try to build the dome in an order different from that in the instructions: some of the short cuts that look attractive have traps in them (we know - we've gotten stuck!).

Many of the holes needed in the assembly of the dome can be “pre-drilled” prior to the actual start of the building project. This allows fiberglass sections to be moved and worked on indoors where you are protected from the weather, have better lighting and in many cases have a more comfortable work area. To help with this process, a “Bolt Hole Drilling Guide” has been developed and added at the end of this manual as an appendice.

Finally, if you make a mistake, don't panic. In most cases you can just take the components apart, drill new holes, and do it over. If you want to, you can always go back later and patch any mistakes with resin (that is one of the virtues of fiberglass!), or simply fill the hole with a short carriage bolt if in an area where it will not interfere with the dome operation. And if you get really stuck, give us a call and we will try to help.

2. Safety Precautions

Constructing a HOME-DOME requires you to follow several safety precautions and use common sense, since the activity does include mechanical and manual operations. Care is needed in the use of tools and you should follow the precautions provided by the manufacturers of any tools you may use. Since you will be constructing a small building, you will need to use step ladders: so be careful. While the fiberglass parts are not very heavy, they are bulky: use care in handling them so that neither you nor the parts are injured. Carefully read all the instructions, and think through your activities before you commence. Make liberal use of props, tape, clamps, or other aids in the construction.

CAUTION

If the dome is to be installed on any support or wall more than three feet above the ground, or in a location with difficult outside access, we **STRONGLY** recommend that you pre-assemble the base ring, dome, shutters, and all fittings on the ground. You will then be assembling the dome in a convenient and safe place. Once pre-assembled, it only takes 30 minutes or so to disassemble the parts. You can then reassemble in place, knowing how the parts fit together, and with direct experience in handling the pieces. In many cases the completed dome can be lifted into place with the proper equipment.

Fiberglass

Fiberglass is really a misnomer: the material is fiberglass reinforced plastic (FRP). In our case, the plastic is an isophthalic (polyester) resin (not epoxy). In its "raw" state, resin is a syrupy liquid. After mixing about 15 drops of catalyst per ounce of resin, it hardens in about an hour. Because the hardened resin is somewhat brittle, it is reinforced with fiberglass for strength, and to prevent the propagation of cracks. The fiberglass can be in the form of woven material which has the resin spread onto and into it, or long fiberglass strands which are chopped into 2 inch pieces, then mixed with resin that is sprayed into a mold.

Fiberglass has many virtues, but also two potential problems:

FIBERGLASS IS FLAMMABLE

FIBERGLASS CAN IRRITATE THE SKIN

Yes, fiberglass will burn, or rather, the plastic in it will burn. Once started, it does burn very hot. Therefore, use common sense as you would with wood or any other flammable construction material. Keep fire and open flame away from all parts of your HOME-DOME. Also, do not let fiberglass dust or trimmings accumulate. Be especially careful about this where there is any risk of flame or fire.

The fiberglass within the FRP is glass, and it can cut or abrade the skin. Sharp edges of the dome pieces can cut, so be careful. Whenever handling FRP pieces, always wear gloves to be on the safe side. Of course, the surfaces of the FRP are smooth, because they have been coated with a layer of resin (called Gel-coat) that covers the glass.

Fiberglass dust can irritate the eyes and skin. When cutting or trimming or filing or drilling — in short, whenever doing something to the FRP that makes dust — always use gloves and eye protection. Also, wear a long sleeved shirt and long pants. In addition, be sure to change your clothes and wash thoroughly when you are done the dusty part. If there is lots of dust, change how you are doing things to reduce the dust exposure! Reasonable care is all that is needed; however, failure to follow reasonable care could lead to eyes or skin that itches for a day or so. Hand lotion can help relieve itchy skin. If itching persists, see your physician.

Construction and Operation Cautions

During construction and operation, there are specific cautions that must be followed. The HOME-DOME observatory is not a toy, so be sure that children (and adults) do not climb upon it. Since the observatory does contain moving parts, users must be careful to avoid injury. Keep your fingers away from the moving parts where they might become caught.

The shutters CAN BE DANGEROUS. Each shutter weighs about 10 lb., and slides on the slot edges. They are normally interlocked, and under control of the user. However, if they should not latch properly, or if they are separated for maintenance work, the shutters (especially the front shutter) can begin sliding with little warning. It is ESSENTIAL that care be used never to let the top or front shutter rest by itself at the top of the dome without proper anchoring (if the two are latched together as they normally are, there is no risk). To help prevent injury, you should consider installing a safety device on the front of the dome to limit unexpected downward movement of the front shutter.

To prevent high winds from damaging the dome, it is essential that the front shutter ALWAYS be fastened when the dome is not in use.

3. Special Assembly Instructions

This section contains special instructions that apply to several parts of the assembly and to special hardware issues. We have written these for the relatively unskilled assembler. However, even those who are skilled in carpentry or other mechanical assembly SHOULD read and follow these instructions, especially concerning leveling the structure.

Nomenclature

FIG 13

Parts of the HOME-DOME observatory have special names. These include the following.

- **Base Ring** – the ring that has the rotation rollers.
- **Reverse Flange** - This is the curved topmost flange that is a part of the top flange of the base ring or wall. The purpose is to hold the dome down in case of wind, and also to provide a drain for any water that might enter the dome.
- **Equatorial Flange** - This is the internal flange at the "base" of the dome quads where the equator would be on the earth.
- **Front of Dome** - The dome is that portion of the observatory that rotates. The front of the dome is the location of the front shutter. .
- **Left/Right Orientation** – Throughout the manual, references will be made such as “left section” or “right side”. In ALL cases, these references are made from the perspective of standing outside the front of the dome looking in.
- **Front of Observatory** - The observatory wall (or observatory building) is stationary and does not rotate. Usually, we define the entrance door to be the "front" of the observatory. These considerations are important when you install the foundation and walls, since you will want the door to be in the proper location relative to where you want to enter the observatory.

Locating Holes

In assembling the HOME-DOME, you will need to drill holes and insert bolts to hold the various pieces together. But how will you find where the holes are to be and what is the hole drilling procedure?

In most cases, we have described the exact hole locations (with measurement values) in the step description located in the text of the manual. We have also recapped all of these in a “Bolt Hole Drilling Guide” attached as an appendice. This guide should be read first, especially to identify holes that are to be drilled before assembly, but in no case should you skip the manual and simply work off the drilling guide. During assembly, if some of the holes do not quite line up, and if you are SURE no assembly mistake has been made, you can use your drill to "open up" the holes to accommodate a bolt. Hole sizes will be given in the instructions (most will be 1/4", 9/32", 3/8" or 5/16").

If you have questions call us for information or guidance. It is important, however, that the correct bolts be used in the correct order. Failing this may cause interference, or may cause you to run out of the proper bolts later in the assembly process.

Drilling and Bolting

FIG 1

Many HOME-DOME parts are held together with carriage bolts or flat head bolts, 3/4 or 1 inch long. Carriage bolts have round tops, with a square shank that catches in the hole, preventing turning of the bolt. Flat head bolts are installed in a countersunk hole. We provide stainless steel carriage and flat head bolts, washers, and nuts to minimize corrosion.

In most cases, bolt holes are drilled before pieces are assembled. Drilling in fiberglass requires use of eye and skin protection, but otherwise presents no problems except that bits become dull after 75-100 holes. If a flat head screw is to be used, you will also need to use a "countersink" to create the sloping hole to accommodate the screw head. If available, use an 82 degree countersink, and cut the material just enough to recess the flat head.

Once the holes are drilled, assemble the pieces by installing the carriage bolt or screw in the proper direction (the instructions will tell you in each case). Be sure the bolt head is snug into the hole. Install a 1/4 inch washer and nut, and tighten. If the nut will not turn, check for fiberglass dust in the threads — clean the nut and bolt and try again. Do not force the nut! A drop of oil may help as well.

If you drill a hole in the wrong location, either re-drill a new hole in the correct location, or, for small errors, enlarge the hole on the "nut end" piece, and install one or more large washers, or metal or wood plates, before installing the nut.

Here are some additional tips for drilling holes in fiberglass, or cutting it:

- Drill a pilot hole smaller than the final hole to keep the drill from wandering during the final drilling.
- A common twist drill will produce a triangular hole. In some cases, this can cause a problem. To prevent this, simply drill a hole a few 64ths smaller than the final hole, then finish drill with the desired size.
- Drilling fiberglass produces fine glass dust. If you leave it in the hole, the dust will get into screw threads and make nuts hard to turn. Clean the holes (rag on a screwdriver) and use a bit of oil on the screw to reduce the problem.
- A drilled hole will usually have a ragged edge. In most places, this is not a problem; however, you may want to know several tricks to prevent this. These include predrilling undersize holes, back up the fiberglass with a piece of scrap wood while drilling, drill partway through on one side, then do the other side. You can also lightly countersink every hole after drilling.

- We often call for use of a countersink (makes a conical hole). If you don't have one, you can use a large bit (e.g. 1/2 inch bit on a 1/4 inch hole) to make the cut. However, be careful not to go too deep. Also, note that the angle of the cone may not match very well the bolt that will go in it (usually 82 deg).
- Sometimes the gelcoat will chip when drilling or sawing. If this is a problem, there are tricks to use. These include putting masking tape on the gelcoat before drilling/cutting, use high speed cutting with low pressure, using fine toothed cutting blades, and drilling preliminary undersize holes.

Leveling the Foundation and Base Ring

The more level the foundation is, the easier your overall installation will be. In any case, the top of your base ring must be level (or at least planar). If the base ring is not level, the dome will not be supported uniformly on its rollers. This can cause a variety of problems not only with turning the dome, but also with the shutter operation as the shutter opening may be distorted. At least 1/4 inch accuracy in leveling is needed; however, 1/8 inch is even better.

While the "bottom line" is to achieve a level base ring, any wall built below the base ring should also be level and/or provide a means of leveling the base ring. Leveling techniques using shims or adjusting bolts are discussed below in the foundation section.

There are many ways to perform the leveling. Here are details on several of the best.

- If you have a transit or theodolite, you can use it.
- If you have a split image transit or eye held level, don't bother. It is not accurate enough and/or is too hard to use for this application.
- String levels are not sensitive enough.
- The human eye can see out-of-plane errors in the ring; however, it is very confusing to identify which portion is too high or low, and hard to estimate the amount. It is also hard to keep track of errors in the portions of the ring crossways to the line of sight, versus those more parallel.
- Carpenter levels, if sensitive, can be used, but will not do the job if simply moved around the circumference. See below.
- Water levels are far and away the easiest and best way to level the base ring or wall. They can be made or bought (about \$15), and are described below. (We once spent two frustrating hours with a carpenter level and split image transit and could not do better than 1/2 inch, but a water level did the job to 1/8 inch in ten minutes!)

Leveling with Carpenter Level

FIG 2

A two to four foot carpenter level can serve to level the structure. However, you will find that if you simply move it along the circumference, it is impossible to level the ring accurately. The problem is the subtle shifts of the bubble as you move around the ring.

If your pier is not yet in place, a much better method is to set up a support at the center of the dome, at a height equal to the top of the wall ring or the item to be leveled. Use a bar from this center to the outer ring, and place the level on the bar. Now as you swing the bar around, you can track which parts of the ring are high or low relative to the center. It is easy then to adjust the wall ring to a level condition.

Leveling with Water Level

FIG 3

This is the best! A water level is made of two see-through containers, connected by a flexible, long tube, filled with colored water. (Hint - Use food coloring.) After adjusting the water levels, one container is set on a reference point (e.g., one spot on the ring) while the second one is moved to different points around the ring where the difference in elevation measured. The water level in the moveable container will rise (or fall) with the fall (or rise) of the level of the point you are measuring when compared to the reference point.

Commercial water levels read directly in inches, so it is easy to make accurate leveling corrections. Homemade water levels will work fine, so long as they don't leak. Water levels are tough to use in freezing weather. Add anti-freeze!

Making the Observatory Circular, and maybe Centered

While only the base ring **MUST** be accurately circular, it is highly desirable that all portions of the dome, including the walls, be circular. On the other hand, while aesthetically desirable, it is not necessary that the observatory be centered on some "magic" point, with all parts concentric (note that the telescope pier need not be at the center of the dome).

Identify the center of the observatory and mark it with a screw driven firmly into the foundation, or a small post sunk solidly into the ground. Mark the exact center of the screw or the post with a small nail driven into it but projecting 1/4 inch. You can now use this as the center for marking the foundation, your foundation bolt circle, etc.

The easiest way to start is to draw inner and outer diameters for your wall or base ring directly on the foundation. You will match the inner edge of the foundation ring bottom flange to the inner diameter that you drew. The outer diameter is there as a reference too, but use the inner mark because it is easier to keep in view.

To check the "centeredness" of successive (higher) wall rings, you will want a "center point" that is at the height of your wall. We will describe one easy method of providing this center.

FIG 2

As you build the observatory higher, you can use a plumb bob from beneath a tripod (surveyor or camera tripod) to establish a center at any height you want. If you have no tripod, nail a box together, or stack cinder blocks so that you can hang a plumb bob over your center point. With a little care, you should be able to perform the centering to about 1/8 inch. In either case, you can then use a tape measure to measure the radius to each point around the wall, so as to show that the wall is both circular and centered.

You will use several dimensions later in the assembly:

Item	Average Outer Diameter (inches)	Circumference (inches)
Base Ring	72.25	227.00
DSR	73.40	230.50*
Dome	74.00	232.48

* Measured 1 inch below the top of the skirt

Stainless Steel Cable

Stainless steel cable is used in several parts of the observatory. In general, the cables we provide are longer than needed. In most cases, you can roll up the excess, tape it, and mount it out of the way. The cable is very strong, and difficult to cut — most wire cutters will not do the job. You can use steel cable cutters, or use the wire cutting portion of a Vise Grip® pliers, such as type 7WR (a wonderful tool — cheap imports are not good). You can also cut the cable using a cold chisel on a heavy steel plate. The cut end will be subject to fraying, and can easily cut the skin. To prevent this, gently unravel 1/4 in. of the cut end, and rinse it in acetone to remove the manufacturing oil. Ravel the end back, and put on a tiny drop of instant Crazy glue (don't touch it, or you will stick to it). This will protect the end against reasonable abuse.

4. HD6 Base Ring Construction

Now we are ready to build the observatory!

The HD-6 includes a 9 in. high base ring (in three sections) which serves as part of your wall. The rollers for the dome are installed in the top flange of the wall.

FIG 9

CAUTION

If the dome is to be installed on any support or wall more than three feet above the ground, or in a location with difficult outside access, we **STRONGLY** recommend that you preassemble the base ring, dome, shutters, and all fittings on the ground. You can then assemble the dome in a convenient and safe situation. Once preassembled, it only takes 30-45 minutes to disassemble the parts. You can then re-assemble in place, knowing how the parts fit together, and with direct experience in handling the pieces.

The wall may be constructed using your own plans, but must:

- be able to handle wind loads
- not twist as the dome is turned
- be water tight and resistant to the weather
- provide a solid, level support for the lower flange of the observatory base ring
- look good

If you are constructing a wall of your own design, we invite you to send a copy of your proposed wall design to Technical Innovations. We can review it, and may have suggestions or cautions that will make the wall easier to build, or otherwise help assure a successful installation.

Overview

In this chapter, you will begin actual construction. You will

- install the base ring on the foundation
- check circumference and make it circular
- bolt it to foundation
- install rollers

We suggest you read the instructions carefully, and then perform the work in the order recommended. Re-check your work at each step. Now, let's go!

Base Ring Preparation and Assembly

FIG 23A

The HD6 base ring wall is in three sections. Although the dimensions are the same, your wall sections will have larger roller holes cut for future electric dome drive installation. Even if not installing ED6 at this time, you should install the sections in the proper order, as shown in Figure 23A. Note that the right front section will have a motor hole at the Clockwise (CW) end, the rear section will have a motor hole at the CCW end, and the left section will have no motor hole.

Note: You may find it easier to install the rollers (see next section), on a work bench prior to assembly of the base ring. [*Bolt Hole Drilling Guide #1 and #2*]

You will notice that the ends of the base ring sections are closed. These ends are held together using two 1" carriage bolts. To assemble, clamp the ends together, drill two 9/32 holes about 1.5 inches from the top and bottom. Install the bolts, washers, and nuts. [*Bolt Hole Drilling Guide #3*]

Although use of the three sections with closed ends assures a correct circumference, you should now check the circumference. With the ring roughly level, measure the circumference (i.e., the distance around the ring about one inch down from the top) with a metal tape rule. Your goal is a circumference of 227 inches (+/- 1/2 in.), corresponding to an average diameter of 72.25 inches. If the circumference is too small, install shims as necessary between sections.

Note that while your base ring has an **average** diameter of 72.25 inches, it is likely not to be an exact circle. That is, across one diameter it will be 72 while another may be 72.5. Base rings can easily be "nudged" an inch out of circular shape (and conversely, are easy to nudge INTO circular shape). To gain a bit of experience, take a few minutes with the base ring on a level surface, and measure -AND WRITE DOWN THE RESULTS- the diameter for at least six different "diameters" (directions) across the ring.

The easiest way to take diameter measurements is use a steel tape from the inside (blue) surface to the opposite blue side of the ring. If you swing the tape measure a few inches left and right, you will note the spot with the longest measurement, which is the diameter.

Try adjusting the ring to become circular to within about 1/4 in. maximum range. This is an easy task, but only if you keep track of your work with a drawing! Mark the mounting foundation once the ring is circular in case it moves while mounting.

If you are installing a rectangular or circular skirt, plan where the joints of the skirt will be placed (in most installations, if a skirt is used, it is placed below the ring). See skirt instructions in a separate section of this manual.

The trick now is to mount the ring (and skirt, if any) onto the foundation, while assuring that it is circular, and getting holes in the lower flange to line up with your foundation bolts or structure!

* If you are going to use lag bolts and anchors for the foundation, you should mark nine hole locations on the Inside of the lower flange (but don't drill them yet). Place the ring on the foundation. Adjust it to be circular to within about 1/4 in. or better. Now use a magic marker and draw the inner and outer outline of the base flange onto the foundation and mark the locations on the inner outline for the foundation holes. After marking the base ring so that you can reinstall it in the same position, remove it. Using your bolt location marks, determine where the bolt locations will be under the base ring. Drill your anchor holes with a masonry bit. Install the anchors. You will likely find that the drill bit will have wandered, but not to worry. Draw a pair of 12 in. guidelines to each anchor on the foundation. Now replace and re-circularize (ugh, what a word) the base ring on the foundation. Using the guidelines and a straightedge, you can easily place new marks on the flange for the exact hole locations. Once the holes are drilled in the base ring, again make sure the ring is circular, and install the bolts.

* If you are installing the dome on a wood surface or on the rectangular skirt, simply place the ring on the surface, make it circular, drill holes, and install your bolts.

Whichever bolt style is used, you must install large (1 1/2-2 in. washers under the bolt heads or nuts as shown, so that the wind and other forces will be spread out on the flanges.



Using your level, adjust the foundation nuts or insert shims to level the wall ring to an accuracy of at least 1/4 inch. Tighten all bolts.

Roller Mounting

You have two kinds of rollers:

- three inch "support" rollers on which the dome rotates
- small, thin "side" rollers that keep the dome centered.

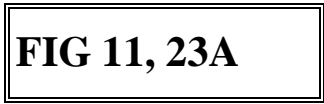

Support Rollers

The three inch support rollers are mounted in the base ring upper flange. Your package of hardware contains rollers plus an appropriate number of flat washers, thread guards (hubcaps) and small cylinders that go inside the roller axle.

Each full length section of the base ring has three rollers. Rollers can be installed either before or after you have put the ring together.

Most of the base ring roller holes are about three inches long to accommodate the rollers. There are also holes for optional rotation motors, an optional azimuth sensor and an access hole. If you do not have motors, install a roller in the middle of each motor drive opening. Leave the azimuth hole empty if you do not have automation. You will use the access hole during assembly of the dome on the dome support ring.

Check that the outer edge of each roller hole is smooth and flush with the inside of the base ring web (the web is the 9 inch high part of the ring). If it is not, use a file or rasp and smooth the fiberglass until it is flush. Use sandpaper to smooth the edges. Wear gloves and eye protection when drilling, cutting, or filing the fiberglass.

Use the template provided or transfer the template design in Fig. 11 to metal or cardboard, or use the dimensions in the figure to locate the roller axle locations. Drill a 9/32 hole, countersink and install a 2 1/4 inch flat head bolt from the outside through the roller. Install the flat washer next to the fiberglass, then the roller with its thread guard in the axle, then the washer and a nut on the end of the bolt. Check that the wheel turns freely. If it does not, remove the wheel and find and remove the interfering material. Make sure the nut is not too tight. [*Bolt Hole Drilling Guide #1*]

Side Rollers

FIG 11

HOME-DOMEs are constructed with a Dome Support Ring (DSR). The DSR horizontal flange is the rolling surface for the dome, while the DSR skirt prevents the dome from moving sideways off the wall. Because of the DSR skirt clearance, the dome can move about 3/8 in. off center. Under some conditions, this movement can cause friction between the DSR skirt and the base ring of the dome, which in turn can increase the force needed to turn the dome. The solution is to use side rollers to center the dome.

In general, you should space the side rollers evenly around the base ring. To install, use the template provide or set a side roller on the base ring so that it projects about 1/8-3/16 in. outward from the base ring (use a 1/8 in. scrap against the outer surface as a template). Mark the center hole and drill a 13/64 hole. (Important — use the correct size bit.) Screw in a self tapping screw (provided) so that the roller turns freely, but without wobble. Place a 1/4-20 nut as a "jam" nut on the underside of the self tapping screw. [*Bolt Hole Drilling Guide #2*]

This completes the base ring installation. We advise that you NOT caulk the wall and base ring seams until the dome has been fully assembled and rotation checked.

Note: Are you installing an Electric Dome Drive? If so, read those instructions — you may want to install some of the hardware (pivot and hook) now.

Splice Plate Installation

Introduction. The Splice Plate is provided with observatories that have reverse flange but no door or DSR Swing-out section. Because the reverse flange covers the DSR, which in turn covers the base ring upper flange, it is desirable to have a way to access to the base ring upper flange. The Splice Plate fills this need. It is not essential for dome operation; however, if you do not install it and later need to get at the top of the base ring, you may need to dis-assemble the dome.

To install, two cuts are made in the front section of the DSR. The Splice Plate is then bolted across these cuts. The plate provides continuous support across this cutout both for rolling, and to maintain the proper slot edge spacing and dome circumference. [*Bolt Hole Drilling Guide #5*]

When access to the base ring is needed, the Splice Plate can be partially disconnected, so the front section of the DSR can be opened. See operating instructions below.

Installation. We recommend that you install the Splice Plate onto the DSR during initial dome construction (it can be done later, but with more difficulty). This work is most easily done on a large, flat table.

- Select the DSR section that will be at the front of the dome. Center the Splice Plate on the front DSR horizontal flange, and transfer the hole locations and the flange cut lines onto the DSR section.. Note whether the cut at the pivot end is curved (if so, the radius is from the pivot bolt). Use a square to extend the cutlines straight down the front of the DSR skirt. Set the Splice Plate aside.
- Drill 17/64 holes in the DSR as located. Countersink for the 1/4-20x3/4 FH screws provided.
- Use a sabresaw or hacksaw to cut the DSR section (DON'T cut the Splice Plate!). Use a fine blade to reduce chipping. Use gloves, and eye protection.
- Assemble the Splice Plate onto the DSR using the screws, washers, nuts and lock-nuts provided. See the figure.
- Note that the latch bolt (at the end with the slot) is fastened directly to the DSR with a standard nut, with a washer and lock nut on top of it. Also use a locknut and washer on the pivot bolt.
- You may need to bevel the vertical cut at the pivot end to allow easy swing of the Splice Plate.
- When installation is complete, clean the cut guide lines off the Splice Plate with mild solvent.

Operation. Normally, the Splice Plate will remain bolted in place, with all nuts tight.

If you need to swing the Splice Plate out to work on the base ring, simply turn the dome to the access hole. Remove the two screws nearest the DSR cutout, and loosen the locknut on the latch bolt (leave the cut-out DSR attached to the Splice Plate). Keep the Splice Plate closed while you

turn the dome to the place on the base ring where you need access. Then open the Splice Plate and work on the Base Ring. Close the Splice Plate before turning the dome again.

When your work is complete, use the access hole to re-install the remaining Splice Plate bolts and to tighten the latchbolt locknut. While you are at the access hole, check that all the Splice Plate bolts/nuts are tight.

WARNING: Never turn the dome until the Splice Plate is swung back into position, and securely latched. Turning the dome with the Splice Plate open can allow the slot opening to enlarge, and result in the dome falling off the wall.

5. Shutters, Rear Cover, DSR Preparation

Overview

You will now prepare the shutters and rear cover. By doing so, the actual dome assembly will proceed quickly, and you will be able to get the dome covered and safe. In this chapter, we will prepare the

- Front Shutter, including glide strips, handle, electric shutter pulleys (if used), and lock
- Top Shutter, including the main bar latches and Shutter Restraint J-Guides
- Rear Cover, including pre drilling flange and shutter catcher holes and mounting the electric shutter motor (if used)
- DSR assembly and mounting

Front Shutter Preparation

FIG 16,16B

Bevel Check. Select the front shutter (of the three shutters, it is the middle width). Referring to the drawing, check that the rear top edge and latch receiving hole edges are beveled properly. If necessary, use a file to bevel the underside of the rear (top) edge and flanges so that it will ride up and over the rear cover. If necessary, bevel the latch receiving hole edges as shown, so that the shutter will disengage the latch. Sand any sharp edges of the shutter (since your hand may touch these at some time).

Handle Installation. Install inside and outside handles using the same pair of 1 in. bolts, with centerline 4.5 inches from the lower/front edge of the shutter. [*Bolt Hole Drilling Guide #9*]

Glide Strips. To reduce friction, the underside portions of the front shutter that slide on the slot edges have low friction strips of High Density Polyethylene (HDPE). These strips are attached using double backed adhesive tape. To assure good adhesion for the strips, you will need to clean the underside of the shutter adjacent to the flanges. Use GOOF-OFF, Fiberglass dewaxer, or other solvent or paint remover, preferably containing methylene chloride.

FIG 19

Four sections of strip are provided, each with a prebent end that fits around the end of the shutter (if the prebending does not fit the shutter, simply heat the prebent end with a hot air gun or propane torch and adjust the bend). You will fit two pieces of glide strip end-to-end on each side of the shutter, where it will slide on the slot edge. Trim the plain ends on a diagonal so that the two pieces are of about equal length and fit the length of the shutter. Clean the blue side, near the flange. To install the strips, start with the prebent end and fit it around the end of the shutter. Removing about 10 in. of wax paper at a time from the double back adhesive tape, press the strip firmly into place. Now apply the second strip that you have cut, start at the pre-bent end, etc.

DANGER

Once the low friction strips are in place, the front shutter will move very easily on the slot edge. As noted in Chapter 2, uncontrolled motion of the shutters can result in damage to the shutters or in serious personal injury. Always have the shutters under control when moving them. NEVER rest the front shutter alone at the top of the dome arc since it can begin sliding with no warning and slam down on the front or on a person. This is not normally an issue, because the front and top shutter are normally safely latched except when they are toward the rear of the dome. You can install the shutter safety device described in Fig 18 or a similar device to limit uncontrolled shutter movement.



FIG 18

Stop Bolt/Electric Shutter Pulleys. If not installing an electric shutter, install two 1 in. carriage bolts 7 1/2 inches from the front edge, 2 inches inside the side flanges (measured on the outside of the shutter). These bolts should project inside, and will rest against the top edge of the rear cover when the front shutter is on the dome in the retracted position. Without these bolts, in the open position the handle would otherwise rest against the rear cover edge. This would pinch your fingers!

If installing an electric shutter, now is the best time to install the Tee-pulleys on the inside of the front shutter. Refer to your electric shutter installation directions for details.

Grommet. Finally, install the vinyl "grommet" to provide a softer leading edge for the end of the front shutter. Push on, or use light hammer blows, as needed. If your head bumps the edge of the partially open shutter, you will appreciate this.

Security and Locks

The HOME-DOME is designed so that the closed and latched dome can be secured simply by locking only one item: the front (lower) edge of the front shutter. Whether or not security is an issue for you, you should use some kind of securing device (bolts or padlocks) to prevent high winds from lifting the front shutter when the observatory is closed. That is, both flanges of the front shutter must be held to the slot edge. Failure to install and use a locking device of some type may result in damage to your dome in event of a big wind storm.

The simplest alternative is to drill a hole in each shutter flange through the slot edge and insert the shutter lynch pins, or 1/4 in. diameter bolts, or a 1/4 in. diameter rod all the way through the four holes.

If using automation and remote control (DDW) make sure locks are removed before operation.

Top Shutter Preparation and Latches

You will now install the latches and shutter restraint system cable guides on the top shutter.

FIG 16B

Latch Installation. The short latch will go on the rear of the shutter and engage the hole in the rear cover, while the longer latch is on the front of the top shutter and engages the hole in the front shutter. The installation of each latch follows the same steps: we describe the front latch installation. [*Bolt Hole Drilling Guide #8*]

Inspect the outside of the top shutter carefully; you will see scribe marks in a line about 5 inches from each end of the shutter with five marks for the **front**, and four marks for the **rear** latch. Drill 5/16 holes and install each latch to the blue side of the shutter with 3/4 in. stainless steel carriage bolts, with the "points" of the latches facing the center of the shutter. Note the countersunk holes for the nuts and washers.

Top Shutter Restraint System J-Guides

FIG 24

The Shutter Restraint System is a cable and spring system that applies a calibrated radially-inward force to the top shutter to prevent wind from lifting the top shutter or the adjacent end of the front shutter. This system allows the observatory to be operated under higher wind conditions because it assures the engagement of the top shutter latches when closing the shutter. [*Bolt Hole Drilling Guide #7*]

You will now install the J-guides on the top shutter. With reference to the figure, each flange of the top shutter has J-shaped guides through which will pass a 1/16 in. stainless steel cable. The cable will connect to the tab of the shutter catcher at the rear of the dome and to a special spring that is mounted on a post toward the front of the dome.

The J-Guides install with the cable hole outside the shutter flange. On each flange, install a guide about four inches from each end. The remaining guides should be installed equidistantly. In all cases, the loop of the guide should be below the flange. Mark, drill, countersink, and install the guides using 10-32x3/4 flat head screws from the INSIDE, with locknuts on the OUTSIDE.

Rear Cover Preparation

FIG 16B

The rear cover is the narrowest of the three and has a downward lip at the top (front) end. The rear cover fills in the circle at the rear of the dome, and stabilizes the two dome halves near the zenith.

Referring to the drawing, check that the bevels are correct in the latch receiving hole in the rear cover, and on the top (front) edges of the rear cover. If not, use a file or rasp to bevel the edges as necessary. Sand the remaining edges if necessary.

Measure and mark the hole locations on the flanges of the rear cover. Drill 1/4 in holes — they should be about 1/8 in. closer to the flange edge than the marks. Countersink the holes. [*Bolt Hole Drilling Guide #11*]

Electric Shutter

If you are using an electric shutter, you should install the shutter motor onto the rear cover at this time (it is easier to work on the level, rather than overhead, later). Refer to the electric shutter instructions for dimensions and locations.

Shutter Catchers

Mark and drill 9/32 holes for the two shutter catcher brackets. They go on the lower right and lower left corners of the rear cover, as shown in the two drawings. The tab on each metal shutter catcher (has a small hole in it) sticks out beyond the edge of the rear cover. (The purpose of the triangular “ramp” on the catcher is to guide the shutter to the outer edge of the catcher during the opening process.)

FIG 14, 24

You can install the shutter catchers now with 1-inch carriage bolts, or do it later after you fasten the rear cover to the dome halves. [*Bolt Hole Drilling Guide #10*]

Dome Support Ring (DSR)

Before installing the DSR on the base/wall ring, use a stiff brush to remove all easily removable grit from the underside of the DSR.

FIG 12

Compare the beveled edges to the drawing, and if you note any corrections to be done, do them now with a file or grinder (please wear gloves and eye protection.)

Pick out the DSR parts to use for the front and the rear. The front section has the swing-out if your dome is the HD6T, or a Splice Plate if you have the HD6S.. Place them on the base ring rollers with the horizontal ends butting against each other and the vertical ends overlapped. Make sure the DSR sections ride around the dome without binding.

Tape a dozen or more pieces of 1/4 in. thick material (such as masonite or plywood) around the outside of the base ring, up between the base ring and the DSR. This will establish the DSR gap and assure a round DSR (because the base ring is round).

Using 24 in. of duct tape on the outside of each DSR joint, tape the DSR sections end to end so that the ends of the horizontal flanges are butted together with minimal, but equal gaps. Check that the circumference near the top of the DSR matches the table in Ch. 3. Once adjusted, drill a single hole through each DSR overlap lip and from the inside install

a 6-32x1 in. screw and nut to join the DSR sections together. The screws can be removed later if you wish. [*Bolt Hole Drilling Guide #6*]

Remove the 1/4 shims, and rotate the DSR so that front section (swingout) is at the front of the observatory. Find the center of the FRONT DSR section. Use a pencil to mark 13 and 14 in. on each side of the center: these will be rough guides for the location of the front slot edges of the quads.

Tape the DSR so that it cannot rotate. You now have the DSR ready to receive the dome.

6. Dome Construction

The wall and base rings are done as well as all the shutter preparation: now comes the real fun. But first, here are some words of caution:

- Two people make the job of holding pieces in place much easier.
- Be sure to follow the sequence of assembly given here. Failure to do so may allow construction errors to accumulate, and cause rotation problems.
- Do not do this job on a windy day. Fiberglass dome halves make great sails. They will not look pretty flying into something or someone.
- At various times during assembly, you may have the halves resting without bolts on the dome support ring. We urge that you use jigs, clamps, or duct tape or other means to prevent a dome section falling off the wall and becoming damaged.
- If the dome is to be installed on a wall more than three feet high, or in a place with difficult outside access, we **STRONGLY** recommend that you preassemble the dome and base ring on the ground. You can then partially disassemble it, and then reassemble the dome in the final location, knowing how the parts fit together, and with direct experience with handling the pieces.

FIG 10,10B

Overview of the Action

Here is a preview the coming action: You will

- install electric shutter cable guide pulley assemblies, if ES6 used
- install the dome halves and rear cover on the DSR, with braces, tape, and bolts
- adjust the dome, then sequentially finish bolting the halves to the DSR.
- install and test shutters
- complete installation of locking system

FIG 13

This portion of the project normally takes less than a day, and will result in a secure dome that is ready to stand up to the weather.

Dome Assembly (Note that both halves of the dome are identical)

Note: if you are installing an electric shutter, you may want to mount the cable guide pulley assemblies as you build your dome. However, do not install the shutter cables until after verifying hand operation of the shutter. See ES6 instructions.

FIG 13,15

Measure and mark hole locations on the underside of the equatorial flanges and predrill 3/8 in. holes. [*Bolt Hole Drilling Guide #12 and #13*]

Measure and mark hole locations for the wind restraint spring post and cable guide posts on each dome half. Predrill holes per guide. [*Bolt Hole Drilling Guide #14 and #15*]

With another person, lift the right dome section onto the DSR. With the aid of the second person, carefully move the section around the DSR until the dome half is close to the correct location. Tape securely in place with duct tape. Repeat with the second dome half.

You now have both dome halves taped to the DSR: BE CAREFUL not to knock them off the DSR!

FIG 14

You will be placing the rear cover on the rear of the dome and bolting it in place. This will "fix" the width of the rear of the slot. To set the front slot opening, and to keep the dome halves in place as you work with the rear cover, install two pieces of wood (e.g., 2x2) as spacers between the slot edges, one at the front of the dome, and one about 2/3 of the way up to the zenith. Make your spacers the right length to produce a front slot opening of 30.5 in. measured at the outside (white) surfaces. Install by drilling a small hole in each slot edge, and installing a 2 in. wood screw into the spacer.

Rear Cover

The rear cover is the narrowest of the three shutters, and has a downward lip at the top (front) end. The rear cover fills in the circle at the rear of the dome, and stabilizes the two dome sections near the zenith.

Referring to the drawing, check that the bevels are correct in the latch receiving hole in the rear cover, and on the top (front) edges of the rear cover. If not, use a file or rasp to bevel the edges as necessary. Sand the remaining edges if necessary.

During the shutter prep stage, you drilled and countersunk holes in the flange, and also drilled holes for the shutter catchers.

Install the rear cover so that it fits over the rear slot edges of the dome halves, with the lower edge of the rear cover approximately 1 inch below the lowest part of each slot edge (be sure to check both sides so that it is not misaligned). You may want to use a prop or C-clamps to hold it in position. You may need to adjust the positioning of the dome halves to achieve the right fit. [*Bolt Hole Drilling Guide #16 and #17*]

FIG 14

Be sure the inner surface of the rear cover is fully seated down against the slot edge, and is not "outward", especially toward the top of the dome.

Using the previously drilled holes in the rear cover as guides, you will drill 1/4 in. holes into the rear slot edge. Start at the bottom of the rear cover. Drill both left and right holes, and install 1 1/2 in. flat head bolts, with washers and nuts. Then work upwards, doing the next pair of left and right holes, and so on. An assistant inside the dome may need to push the slot edges outward against the insides of the rear cover flanges.

When the rear cover is bolted on, you have the two dome halves joined together, resting on the DSR with tape holding the dome and rear cover to the DSR.

Dome Inspection and Final Bolting

You will now install the equatorial flange/DSR bolts while assuring that:

- the slot opening is 30.5 in. (outside)
- the dome is centered on the DSR

Check the front slot opening. If it is not 30.5 in. outside, adjust the dome halves as needed.

Check each of the slot edge tabs where they overhang the DSR. Each slot edge should be within 1/4 in. of the DSR and must be equal for the left and right dome halves, and front and rear. Adjust the dome halves as needed so they sit evenly on the DSR.

The exterior of the dome will overhang the DSR by about 1/4 inch on the front and back, and be flush on the sides. If the dome overhangs more on one side than the other, and the DSR sections have not disconnected, simply move the dome over (easy to do since the rear is only taped in position).

Now you will install the bolts to connect the equatorial flanges to the DSR, working first on the front and the rear bolts. Be sure to use eye protection! Another hint: this step is easy to do if one person is inside the dome doing the drilling, and a second person is outside, turning the dome and checking to see that the dome remains evenly placed on the DSR. [*Bolt Hole Drilling Guide #18*]

You will use the access hole to drill down through the dome equator flange. With the dome centered, use the previously drilled holes in the equatorial flange as a guide for drilling 1/4 in. holes down through the DSR.

Drill and install the 1R and 1L bolts first, followed by the 6R and 6L bolts.

FIG 15

Recheck the dome. If everything is OK, you will proceed with the remaining bolts.

Rotate the DSR/dome so that each hole in succession is above the access hole. At each location, drill the hole, countersink the DSR from beneath, and install a 3/4 flat head bolt upwards. When you are done, remove the DSR lip bolts (or leave them in if they do not interfere with rotation.) Turn the dome! If you assembled the dome correctly, it will turn easily. But don't panic if it doesn't. See Sec. 10 for how to investigate and fix any problems. Note: fix any rotation problems BEFORE continuing. And don't caulk the base ring, wall joints, or dome equatorial flange until you have a smoothly operating dome.

Shutter Installation and Initial Operation

Install the shutter catchers onto the rear cover using the previously drilled holes and 1 in. carriage bolts.

Place the front shutter on the rear of the dome so that the handle is up and toward the front, and the flanges straddle the rear cover. The shutter will not rest on the shutter catcher, because the handle will rest against the top edge of the rear cover.

Install the top shutter (long latch to the front) so that it rests in the shutter catcher, and straddles the front shutter.

You will now close, then open the dome. Enter the observatory, and grasp either handle of the front shutter. Pull the shutter toward the front (i.e., up and over). It should slide easily, though you will note its weight. As it moves past the top of the dome, the front latch of the top shutter will drop into the hole in the front shutter, so that you will begin moving both front and top shutters together. As the front latch and hole become visible on the underside of the front shutter, visually check that the latch is **fully seated**.

Assuming that it is, still keeping your hand on the handle, continue pulling forward and down. The rear latch on the top cover will engage the rear cover, and the shutters will lock into the closed position.

Note: if the front latch does not **fully** engage, restore the shutters to the back of the dome, and retry. If the latch does not seat properly on the second try, DO NOT attempt to use the shutters until you have found and corrected the problem (See Chapter 8).

To open the shutters, simply slide the front shutter up and back. Both the top and front shutter will move back. As the front latch rides over the rear cover, it will partially unlatch, completing unlatching when the top shutter rests on the shutter catcher. Continue moving the front shutter back until it is seated. DO NOT let go the front shutter until it is fully opened and in the rear, as it will slide uncontrolled to the back where it may be damaged.

FIG 16B

As you open the shutter the first few times after the observatory is constructed, you should make several observations as you slide the shutter up the first foot or so:

- watch that the top shutter moves back as the front shutter is slid upward
- look up inside to check that the rear latch has disengaged from the rear cover
- look up inside to check that the front latch is still partially engaged (i.e., still in the hole)

Your last step is to check that the latches fully seat when the dome is closed and front shutter locked down (so that the wind cannot lift either shutter). Go inside the dome, and pull the shutters closed. Check that both latches not only dropped into their receiving

holes, but that they fully lock the rear cover and front shutter. If not (for example, if the inside handle is preventing full closure), be sure to correct the problem before continuing. Shutters have never blown off a HOME-DOME that is properly secured!

We strongly recommend that as soon as you have verified full shutter latching, you drill holes in the shutter and flange and use spare bolts or the lynch pins from your kit to secure the front shutter.

Constructed according to these directions, the past zenith opening of the dome shutter will be about 16 in., and the front shutter when closed will extend about 2 in. below the end of the dome slot edge.

Protect Your Dome

At this time you should complete the installation of the lynch pins, bolts, or other means to secure the dome against wind. You should use your locking device every time you close the dome. Remember, when closed and locked, the shutter latches must be **fully** engaged in the latch receiving holes. Failure properly to lock down the front shutter to the dome may result in severe wind damage to the structure.

8. Finish Work

Overview of Finish Work

There is only a bit of finish work left. You will need to complete or install a number of items that help protect the observatory and make it safe and enjoyable to use. These items include

- finish installation of the shutter restraint system
- finish installation of the electric shutter (if used)
- finish installation of the electric dome rotation (if used)
- install a summary instruction sheet.

Shutter Restraint System

FIG 24

The Shutter Restraint System is a cable and spring system that applies a calibrated radially-inward force to the top shutter to prevent wind from lifting the top shutter or the adjacent end of the front shutter. This system allows the observatory to be operated under higher wind conditions because it assures the engagement of the top shutter latches when closing the shutter. Of course, it also prevents the wind from blowing the shutter off the dome when the shutter is open. If this system is not installed, the Home-Dome should NOT be operated if the wind is more than about 15 mph, a very light breeze. With the system installed, the dome is safe to operate to about 30 mph, a very stiff wind. Note that this system does not affect the wind strength of the properly closed observatory — that is a function of the strength and design of the fiberglass, latches, and front shutter hold-down. However, it will improve the resistance to shutter lift off if the shutters are not fully and properly latched.

Description of Operation. As you see in the drawing, J-shaped brackets are bolted to the white side of both flanges of the top shutter. A cable passes through the holes in these brackets. Each cable is anchored to a shutter catcher bracket at the rear of the dome, and to a special spring that is mounted on a post toward the front of the dome.

When the shutters are in the rear, the cable will act as a restraining force inward on the top shutter, so that the wind cannot lift it away from the dome. The spring is designed so that it has only a limited travel, so even a high wind cannot do more than lift the shutter an inch or so.

You will adjust the cable tension when the shutter is closed. The spring and cable will be at low tension, virtually zero. Here is the reason: When you are opening the shutter, the front and top shutter move backwards until the rear latch leaves its latch receiving hole. This raises the rear of the top shutter. Again, when the front latch disengages from its hole in the front shutter, the top shutter raises up. You want no tension on the cable at any point of the opening or closing because it might prevent one of the latches from coming out of its hole.

Where the cable is outside the top shutter J-guides, small cable posts mounted on the dome keep the cable from sliding across the dome surface.

You have already installed the J-guides on the Top Shutter. You will now install the remaining items.

Spring Post. Locate the pre-drilled spring post hole (forward most hole in the wind restraint post holes) and install the spring post and spring using the carriage bolt supplied. Repeat for the other side of the top shutter.

Rear Cable Bracket. The rear cable bracket is a part of the shutter catcher already installed. The bracket tab has a small hole and projects out from the rear cover.

Cable Guide Post. The cable posts prevent the cable from sliding across the dome (this is primarily an aesthetic issue). Install the small cable posts in the 4 remaining pre-drilled wind restraint holes. Complete on both side of the dome.

Cable Installation. One end of the cable attaches to the spring, the other end to the rear bracket. One end of the cable has a permanent termination loop, the other end is bare where you will use a split bolt as a cable clamp. You should decide whether you want the cable clamp at the rear or at the top front of the dome depending on where it is more convenient for you to adjust the cable tension. Most installations have the permanent loop at the spring post, with the clamp to adjust tension at the lower rear. Assuming this installation, feed the free end of the cable through the spring bracket and through the loop.

With the top shutter back in the shutter catcher, feed the free end of the cable through the J-guides and attach the end to the spring rear bracket with the cable clamp. You will adjust the tension later.

Cable Tension Adjustment. With the shutters **closed**, adjust the cable tensions so that the cables are LIMP, i.e., NO tension. Tighten the cable clamps tightly and test the system by operating the shutter. You should see no more than a very slight spring tension as the shutter opens and the latches leave the receiving holes. You should notice no

increase in the force required to operate the shutters compared to no wind restraints. If you see a significant increase in shutter force, relieve the tensions slightly and retry.

Notice: This Shutter Retraint System is somewhat sensitive to errors in the shapes of latches. If the shutters do not want to unlatch, please see Chapter 8.

Anti Rotation Bolts

Although optional, anti-rotation bolts are desirable for preventing rotation when you are NOT observing and for doubly assuring that severe wind storms do not damage the dome. We suggest using 1/4 or 3/8 in. diameter carriage or other bolts, washers, wing nuts, or other devices convenient for you. You should drill four holes down through the equatorial flange, DSR, and base ring. You can then insert long bolts to prevent rotation when your dome is not in use. During windy periods, especially when you know a severe wind storm is coming, it is desirable that you place nuts on these bolts and tighten them to make sure the wind cannot lift the dome off the base ring.

Caulking

If you are satisfied with the dome assembly, it is time to caulk the joints.

If it is too cold or wet to caulk, you may use vinyl tape from a hardware store and apply it to the joints, or you can just leave the joints uncovered (normally VERY little rain will get in). Do not use duct or electrical tape, since these leave sticky residues that are difficult to clean. Tape should be removed as soon as the weather improves. Use tape or low quality caulk if you plan to disassemble the dome in a short time (good caulk is harder to remove!).

If the dome has been exposed to rain, it almost certainly has water between some of the flanges: it can stay there for weeks! Before caulking, the water should be removed or else the caulk will not make a good bond. You can wait, and verify dryness by looking into the joints or inserting a paper strip. But an easier way to get the water out is to use a hair dryer or compressed air or similar means to blow out the water.

Our experience is that simply injecting caulk into the (dry) exterior seams from the outside forms a completely effective seal. We provide clear silicon caulk (the clear ends up looking better than white). With the seams clean and dry, inject a smooth bead. We recommend that you not try to smooth the bead with your finger or other tool because then the silicon caulk tends not to form a smooth surface. Extend the caulk down along the skirt side joints on the DSR.

If you want to inject caulk deep into the seams, you can do so by loosening the flange bolts and installing small wedges. Inject caulk into the opening, being careful not to overdo it at the points where the DSR sections abut. You do not want caulk to ooze down into the roller area. Remove the wedges, and tighten the bolts.

If there is a gap between the bottom of the wall and the foundation, now is the time to fill it. We recommend expanding foam, which you can inject into the gap. It will ooze out inside and out, but after it hardens, you can cut off the ooze with a sharp knife. Paint the outside with latex paint so the sun won't cause deterioration.

Instruction Sheet

Elsewhere in this manual we have provided a summary of the use and maintenance instructions that apply to your observatory. We recommend that you post a copy in the observatory. If a user did not participate in constructing the dome, be sure to go over the instructions so that the observatory AND the user are protected!

9. Problem Solving

This section describes some problems that may occur and how to solve them. Most problems are easily solved with a careful, step by step approach. In the event that some parts need to be modified, or if portions of the dome must be disassembled and then reassembled, don't despair: these activities are easy to carry out. You will find that fiberglass is very forgiving of errors, and that fixing problems is usually very easy, once the problem is understood. If you find that you need to, call Technical Innovations and we will try to help.

Dome Rotation Problems

One possible problem at this point is that the dome does not turn easily, i.e., it turns easily at some points of the circle, and not at others, or it may turn in one direction and not the other. A systematic look will generally locate the problem.

First, check that all the blocks are removed, and that there is no foreign material (tape, wood scraps, etc.) between the DSR and the base ring. A bolt or nut under the DSR can make horrible noises at particular rotation points, and also resist rotation. Check that the DSR lip screws have been removed (or are not touching the base ring). Check that the rollers are all clean. Check that nothing is catching on a sharp edge (this will normally show up as a sudden stoppage of the rotation). If this is the case, find the offending spot and bevel or modify it. If you think the problem is under the DSR (e.g. a lost bolt), see the section "**Base Ring Service**" below for how to inspect that area safely.

If nothing is catching on an edge, i.e., the dome simply is much harder to turn at some points, the problem is likely to be binding of the DSR against the base ring. This can have several causes:

- the Base Ring was made too large
- the DSR was made too small
- Base Ring and DSR are out of round.



FIG 21

Check your base ring and DSR circumference measurements. (Compare to the chart in Chapter 3.) The DSR circumference should be at least 2.5 in. greater than the Base Ring, giving a DSR diameter at least 0.8 in. greater than the base ring. If the DSR to Base ring diameter difference is too large, (Case 3 in figure), binding will not occur but you will have substantial side to side movement as you turn the dome. If the DSR to base ring diameter is too small (Case 4), binding will occur.

Case 1 shows correct circumferences, with the dome centered on the base ring. As you turn the dome, you can push the dome off center (Case 2), given the DSR-base ring gap. This is normal.

Now, suppose the circumferences are OK, but the base ring and/or DSR are out of round. If centered, Case 5 shows that the gap may be uniform around the dome. But if you turn the dome 90 deg. (Case 6), you will see a different pattern of gap measurements. If you suspect this case, carefully take several sets of measurements, pushing the dome in both directions, and compare the results to determine exactly what is happening.

The most common cause of the problem was that the base ring was not circular during initial assembly (e.g., was forced onto improperly located foundation bolts). If the base ring was out of round, this would then cause the DSR to assume an out of round shape when bolted to the dome halves.

In either case, examine the situation carefully, make careful measurements, and think out carefully what is happening before making changes. If necessary, set up a good center point so that you can measure the "radius" of the Base Ring and DSR at different points on the circumference, and plot the results. Proceed step by step, rather than "just trying things". Try loosening the bolts holding the item (e.g. one of the DSR sections) to its improper shape, modify the shape (use people power, twisted ropes, duct tape, clamps, or other means), drill new holes, and install and tighten new bolts. Don't worry about making extra holes in the DSR or other parts (the extra holes won't show, and the parts are all sufficiently strong to accommodate the extra holes).

FIG 16

Shutter Engagement Problems

Shutter or latch engaging problems are nearly always caused by the edge of one item catching the edge of another. To solve, simply examine closely the location of each shutter as you have the problem, and identify the offending points. Fix it by beveling or adjusting the interfering edge properly. If the problem is a cavity (rather than a projection), fill the cavity with epoxy or polyester resin (or BONDO from an Auto store) and file to obtain the desired shape.

If the latches of the shutters do not properly engage, do NOT use the dome until the problem is corrected.

Shutter Dis-engagement Problems

When the shutter is opened the first few times after the observatory is constructed, you should make several observations as the shutter moves up the first foot:

- watch that the top shutter moves back as the front shutter is slid upward
- look up inside to check that the rear latch has disengaged
- look up inside to check that the front latch is still partially engaged (i.e., still in the hole)

When opening, if the front latch disengages while the rear latch remains engaged (the opposite of what should happen), then when the rear of the front shutter reaches the latch it will force a disengagement. The top shutter will then slide to the back OUT OF CONTROL and will usually break the shutter catchers. This can damage the shutter, and is dangerous and must be corrected.

The cause of this behavior may be one or both of the following:

- some condition at the rear latch or hole prevents easy disengagement of the rear latch
- some condition allows the front latch to disengage too easily.

The top shutter rear latch should disengage very easily as the top shutter is pushed back. Difficulty can be caused by:

- The rear latch may be excessively rounded at the ends of the rear face with a perpendicular bevel ("A" in figure). Because the rear edge of the hole is triangular, the ends of the latch will initially contact the rear of the hole, and a perpendicular face will not slide up out over the edge. Correction is to cut off the ends, or modify the bevel from perpendicular to sloped (as is the remainder of the rear face)
- The rear of the rear latch hole may be beveled too sharply ("B" in drawing). This can cause grooves or cuts in the rear face of the latch which worsen the problem. To fix, sand the face to less than 45 deg with smooth edges. If the rear face of the latch is grooved, sand or shave it smooth.
- The front of the hole may be beveled too sharply, causing the latch to jam in place ("C" in drawing). Sand the front of the hole to a more vertical face, and smooth the edges.

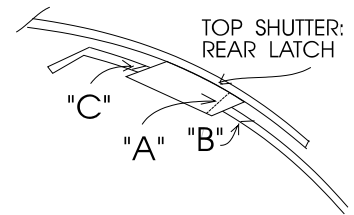

The front latch should NOT disengage until the front latch passes over the down lip of the rear cover and the rear of the top shutter has reached the shutter catchers. Too easy disengagement can be caused by lack of vertical bevel on front face of latch. Correction is to create a bevel about 1/4 in. high (sand, plane, or cut).

Note, sometimes there may be excessive force required to disengage the front latch even when they are back in the correct position. This may be caused by warped shutters, a front shutter glide that has come loose, excessive electric shutter tension, or other problems that lift the front of the top shutter and/or the rear of the front shutter away from the dome. The cure may be to reduce an excessive front latch vertical bevel, or to make vertical the front edge of the front hole.

Shutter Blow-off

With the shutter restraint system in place, it is virtually impossible for the shutters to blow off. If the top and/or front shutter should blow off your dome, it is almost always that the latches were not fully engaged holding the top shutter to the rear cover and front shutter, or that the front shutter was not fastened to the front slot edges. Please review the

shutter installation instructions, and recheck your latches and locking system. Never use ropes or bungee cords to hold the shutters in place.

Base Ring Service

If you identify a problem that requires you to work under the DSR, you can do this WITHOUT disassembling the dome from the DSR. Simply turn the dome to the position needed, and open the DSR splice plate, thus allowing access to the base ring beneath. However, remember, UNDER NO CIRCUMSTANCES should you turn the dome unless the DSR splice plate is closed and bolted. Failure to follow this rule may cause the dome to fall off the base ring.

9. Use and Care of your HOME-DOME

Your HOME-DOME should give you many years of faithful service. Feel free to modify it, drill holes in it, and generally add your own personal touches to it. The walls are strong, so you can use any fastening means (including fiberglass) to add desks, benches, etc. as you desire.

Use the dome, but exercise reasonable care: it is NOT a toy. Don't let adults or children on top of the dome. And keep flames away: remember, fiberglass is flammable. If you use a heater, be careful to keep it away from contact with the fiberglass.

Your closed and locked observatory is designed to withstand the full range of normal adverse weather conditions, including extremely high winds. However, it is not designed for occupied use under high wind conditions. It is not possible to place a specific limit on the wind velocity that is acceptable, although most users find that winds above about 30-35 mph are not comfortable. If you wish to use the dome under higher wind velocities, you should contact us for additional guidance and recommendations.

Although your dome is very weather tight, be sure to cover your telescope with a sheet of plastic when not in use. If the air temperature drops so that the dew point is below the dome temperature, condensation can form, and drip from the top of the dome. This is rarely a problem except for domes attached to a house or other source of water vapor (in that case, you must have double doors or other means of keeping the water vapor out of the dome). If condensation is a problem, try a small heater, dehumidifier, or 100-200 watt lamp near the center of the dome and call us for additional help.

Your HOME-DOME requires very little care. Overall, the care of the dome is similar to that of a fiberglass boat, although since the dome is not in a marine environment, it will require less maintenance (and there is little chance for barnacles to grow!).

If you wish to keep it looking as new as possible for as long as possible, wash it with mild detergent (no abrasives) every 6-12 months to remove dirt and grime (add bleach if algae is a problem). You may want to apply rubbing compound and wax to the outer surface to help it remain "clean looking" longer, and help protect the finish. If the appearance is important to you, this should be done as soon as you build your dome if it is located close to trees, or if you have lots of dirt in the rain in your area. With occasional waxing the surface should last for many decades, though it may become slightly yellowish. You may wish to talk with auto or marine or boat supply stores for advice or materials for fiberglass maintenance and repair.

Three brands of fiberglass treatment that we have tried and like are

- 3M Marine Fiberglass Restorer and Wax (combines rubbing compound and wax in one application)

- IOSSO Fiberglass Reconditioner (restores color, removes oxidation and chalking, toll free number 1-888-747-4332)
- Meguiar's Cleaner and Wax (excellent cleaning and shine, easy to use)

It is possible that the surface of the fiberglass may become chipped or damaged during assembly. Or, after many years, it may develop some surface crazing or blisters. Normally, these chips or discolorations will cause no functional problems. That is, while they may affect appearance, they do not significantly affect the strength of fiberglass beneath. However, if you do wish to repair the surface, you can use epoxy or polyester resin to cover the area for a functional fix, and add gel-coat for an aesthetic fix. Contact an auto or any marine or boat supply (see the Yellow Pages) for a fiberglass repair kit containing white Gel-coat (i.e., resin with white pigment) which can be applied easily.

If major damage to the dome occurs (e.g., you forgot and left the dome open during a major windstorm), virtually any damage can be functionally repaired using a fiberglass repair kit. You'll find a kit for this purpose in an auto parts shop or marine supply. If you wish, you may contact Technical Innovations for advice and/or replacement parts.

After 15-25 years, the surface may begin showing its age, usually by a dulling or chalking of the finish. (But then, so will we all!) Unless the surface is damaged, the only care really needed is wax. However, if you wish to repair the surface, you may reapply gel coat, or you may paint the dome using a high grade epoxy paint. In either case, you will need to prepare the surface properly by cleaning and some abrasion. Again, give us a call, or check with your local marine or auto supply stores for advice and materials.

Fiberglass Parts, 6' domes



Two dome halves, slot edges up



Dome Support Ring (one half of ring is shown)



Three shutters, L to R: Front Shutter, Top Shutter, Rear Cover (with lip at top end)



HD6S Base Ring, 9" high, 3 sections

Bolt Hole Drilling Guide

HD6

Introduction and Terminology

When the dome has not been preassembled, there are a number of holes that need to be drilled in order to attach one fiberglass section to another or install miscellaneous add-on parts.

Throughout the process, it is extremely important to maintain roundness and levelness, while keeping a pleasing “cosmetic” appearance at the different “seams”. Most times there will be a hole going through two pieces of fiberglass, which will then be bolted tightly together. Even though the sections must be moved around until the final position meets the specifications, (especially base and wall rings), we know closely enough where the holes will be located to be able to drill one of the holes (“Guide”) then use that hole as a guide when we drill through the second piece (“Final”). The drilled identified as “Final” will, in most cases, be immediately followed by bolting the part or adjacent fiberglass section, together.

Base ring sections join together end-to-end (“Overlap”).

The reference “Right” or “Left” has the orientation of standing outside the front shutter opening location (or “Home” position), facing the dome and looking in.

Construction Overview

The construction step sequence (detailed in the manual), is as follows:

1. Installation Preparation – Foundation, leveling, tools, organization and planning
2. Pre-drilling
3. Base ring prep and install
4. Mounting base ring to foundation
5. Rotation system install (wheels and side rollers)
6. Prep and install DSR
7. Prep dome quadrants
8. Install rear shutter panel
9. Install dome halves to DSR
10. Prep front and top shutter sections
11. Install shutter
12. Finish items

Bolt Hole Drilling Guide

1. Wheels, Final

Locate the wheel cutouts in each base ring section (on the underside of the reverse flange). Find the center of each cutout and measure down the outside wall of the base ring 7/8” (or use the template provided with the dome hardware). Drill (5/16 inch bit) and then countersink the outside of the hole to a depth that results in the head of the 2 ¼ ” Flat Head bolt to be flush with

the outside wall surface. There are two large cutouts for the optional ED motor assemblies. If you are not installing the ED10 system, drill similar wheel holes centered on these two cutouts.

2. Side Rollers, Final

There are 9 side rollers that get distributed approximately equal distance apart around the top surface of the base ring (under the reverse flange), between the wheels.

The side roller is mounted horizontally on the top surface so that it extends between 1/8 and 3/16 inch out from the base ring wall surface. Measure 3/4 inch inward (or use template) and mark for the Side Roller mounting hole. Drill out these holes using a 13/64 drill bit.

3. Base Ring, Joints, Final

The 120 degree base ring sections have one flat mounting surfaces (mounting flange to the inside) on each end. The three sections for the base are fit together in the proper order (see Figure 23A) until a continuous circle is formed on top of the mounting surface. Using clamps, this ring is adjusted until it is circular and meets the circumference measurement tolerances. Two holes are drilled in each of the three matched up joint flanges, 2 inches down from the top and 2 inches up from the bottom approximately centered on the flanges, (9/32 inch bit). The sections are bolted at this point to form the solid base ring.

4. Base Ring, Mounting Flange, Final

With the bottom ring of correct circumference, circular, and placed on the mounting surface at the desired location, the anchor holes can be drilled. Anchor holes will be made through the bottom flange of this ring approximately every 12-15 inches around the circumference. Using a small (1/8 inch) bit, drill "Guide" hole through the flange and into the mounting surface below. Depending upon material the ring may need to be moved and holes for bolt anchors drilled out. The ring is moved back into place and the mounting holes in the fiberglass flange drilled out to match the anchor bolt size decided upon (normally 3/8 inch bolt).

5. DSR Splice Plate, Final

With the splice plate properly positioned at the center of the front DSR section, use the holes in the plate as guides to drill 17/64 inch holes in the DSR. Countersink the holes on the bottom inside of the DSR for the flat head bolts.

6. DSR overlaps, Final

With the wall/base rings of correct circumference, circular, and bolted together, the two DSR sections are set into place with each end overlapping the adjacent. Once adjustments are made to obtain the correct DSR circumference, a 6/32 hole is drilled in the center of each overlap section.

7. Top Shutter, J-Guides, Final

Four J-Guides (2 holes each - 3/16 inch bit) are mounted onto each of the side flanges of the top shutter panel. One of the J-Guides should be used as a template for the pair of holes, and positioned such that loop section only extends past the flange edge. The first pair holes are drilled 4 inches in from one end of the shutter panel and the second pair 4 inches in from the other end. The remaining 2 are evenly spaced between the first two (approximately 12.5 inches between each). All 16 holes (both sides) will be counter-sunk on the inside of the flanges to prepare for the 10-32 flathead machine screws.

8. Top Shutter, Latch Bars, Final

The shutter latch bars (long – 5 holes and short – 4 holes) are mounted near the ends of the top shutter. The long is near the front edge and the short near the rear edge. In both cases a centerline should be drawn 5 inches in from each shutter edge. The latch bars are each centered on the shutter with the latch holes centered on that line. Mark the bolt hole locations and drill 9/32 inch holes at each point (total of 9 holes)

9. Front Shutter, Handles, Final

The shutter handles (two, mounted back-to-back; inside and outside) are attached onto the front shutter section, near the front. The handles will be mounted on a centerline which is 4.5 inches in from the front edge of the front shutter section. Center the handles on the front shutter (each bolt hole will be approximately 6 inches in from the outside shutter edges. Use one handle to mark the bolt hole locations then drill the two 9/32 inch holes.

10. Rear Shutter, Shutter Catchers, Final

The pair of shutter catchers (which are mounted on the outside at the bottom of the rear shutter panel) have a right and a left unit. They are positioned such that they are flush with the bottom and side (each outside bottom corner of rear shutter panel), and the “arm” with wind restraint cable hole, extends out from panel. Mark and drill four 9/32 holes (two for each shutter catcher).

11. Rear Shutter, Side Flanges, Guide

Ten holes (9/32 inch bit) are centered and drilled (5 on each side) through the side flanges of the rear shutter panel. From the top end (next to large latch slot and tapered edge), the first hole is drilled 2 inches down. A second hole is drilled 4 inches up front the bottom of the rear tab, followed by hole 3, 4 and 5 evenly spaced between these two (approximately 9 1/4 inches apart). All ten holes will be countersunk on the outside of the shutter panel flange.

12. Right Dome Half, DSR Flange, Guide

Six holes (9/32 inch bit) are drilled into the bottom horizontal, DSR, flange of the right dome half. The first hole is drilled 5 inches from the front edge followed by the next five, each approximately 13.5 inches apart. The sixth bolt will also be 5 inches from the rear edge.

13. Left Dome Half, DSR Flange, Guide

Six holes (9/32 inch bit) are drilled into the bottom horizontal, DSR, flange of the left dome half (exactly the same as the right dome half). The first hole is drilled 5 inches from the front edge followed by the next five, each approximately 14 inches apart. The sixth bolt will also be 5 inches from the rear edge.

14. Right Dome Half, Wind Restraint, Final

The wind restraint system includes Spring Post Assembly and 4 cable posts on each side of the dome. Most people find that it is easiest to drill these holes while the dome half is still on the ground. These holes are drilled through the dome itself, just outside the shutter flange.

Start at the rear (DSR level) and measure upward 14 inches; go out from the shutter flange (on the dome surface) 2 inches and drill the first rear ¼" cable post hole.

Measure upward from the first rear cable post hole 10 inches; go out from the shutter flange (on the dome surface) 2 inches and drill the second rear ¼" cable post hole.

Start at the front (DS level) of the dome half and measure upward 28 inches; go out from the shutter flange 1 inch on the dome surface and drill the 9/32" cable spring post hole.

Measure upward from the cable spring post hole 14 inches; go out from the shutter flange (on dome surface) 2 inches and drill the first front ¼" cable post hole.

Measure upward from the first front cable post hole 14 inches (just beyond zenith); go out from the shutter flange (on the dome surface) 2 inches and drill the second front ¼" cable post hole.

15. Left Dome Half, Wind Restraint, Final

NOTE: Left Dome Half, Wind Restraint Final is exactly the same as Right Dome Half

Start at the rear (DSR level) and measure upward 14 inches; go out from the shutter flange (on the dome surface) 2 inches and drill the first rear ¼" cable post hole.

Measure upward from the first rear cable post hole 10 inches; go out from the shutter flange (on the dome surface) 2 inches and drill the second rear ¼" cable post hole.

Start at the front (DS level) of the dome half and measure upward 28 inches; go out from the shutter flange 1 inch on the dome surface and drill the 9/32" cable spring post hole.

Measure upward from the cable spring post hole 14 inches; go out from the shutter flange (on dome surface) 2 inches and drill the first front ¼" cable post hole.

Measure upward from the first front cable post hole 14 inches (just beyond zenith); go out from the shutter flange (on the dome surface) 2 inches and drill the second front ¼" cable post

16. Rear Right Dome Half, Shutter Flange, Final

The rear shutter panel is placed so that it straddles the shutter flanges at the rear of the two dome halves and is positioned such that the bottom of the panel extends approximately 1 inch below the tab edge at the rear of the dome shutter flange. Using the guide holes drilled into the rear shutter panel, drill 9/32 inch holes through the rear right dome quadrant shutter flange.

17. Rear Left Dome Half, Shutter Flange, Final

The rear shutter panel is placed so that it straddles the shutter flanges at the rear of the two dome halves and is positioned such that the bottom of the panel extends approximately 1 inch below the tab edge at the rear of the dome shutter flange. Using the guide holes drilled into the rear shutter panel, drill 9/32 inch holes through the rear right dome quadrant shutter flange.

18. DSR, Final

The two dome halves are properly positioned on the DSR with spacers maintaining the front shutter opening width. The guide holes in the dome half DSR flange are used to drill 9/32 inch holes through the DSR. These holes are then countersunk on the bottom side of the DSR for flathead machine screws

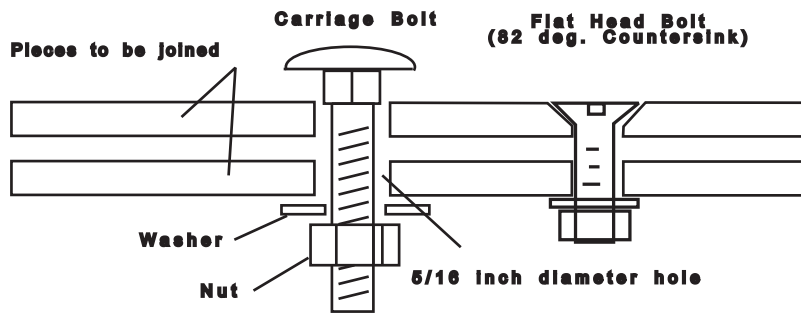

Figure 1
Bolt Detail

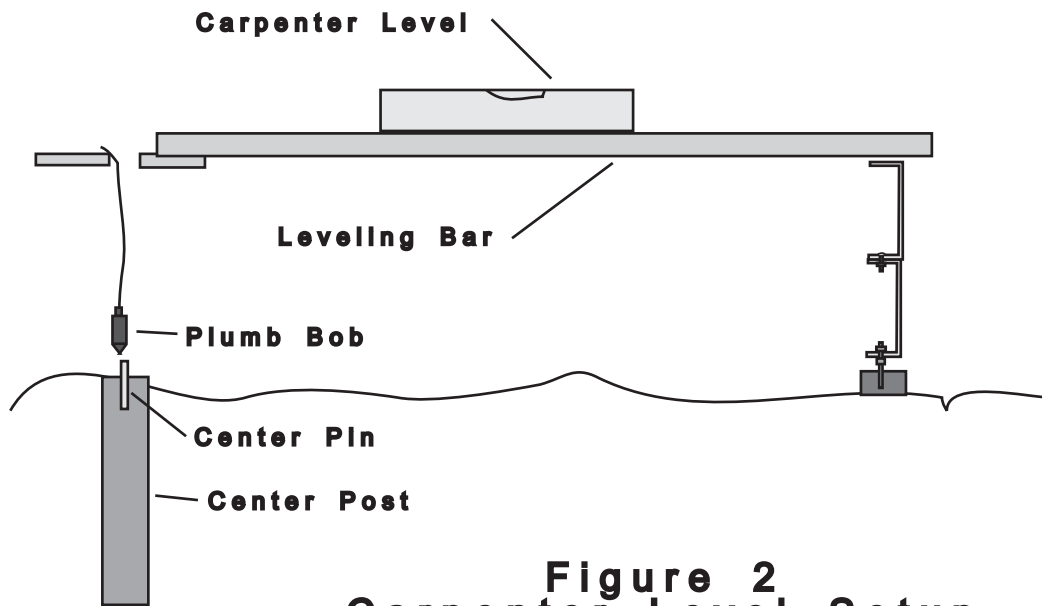
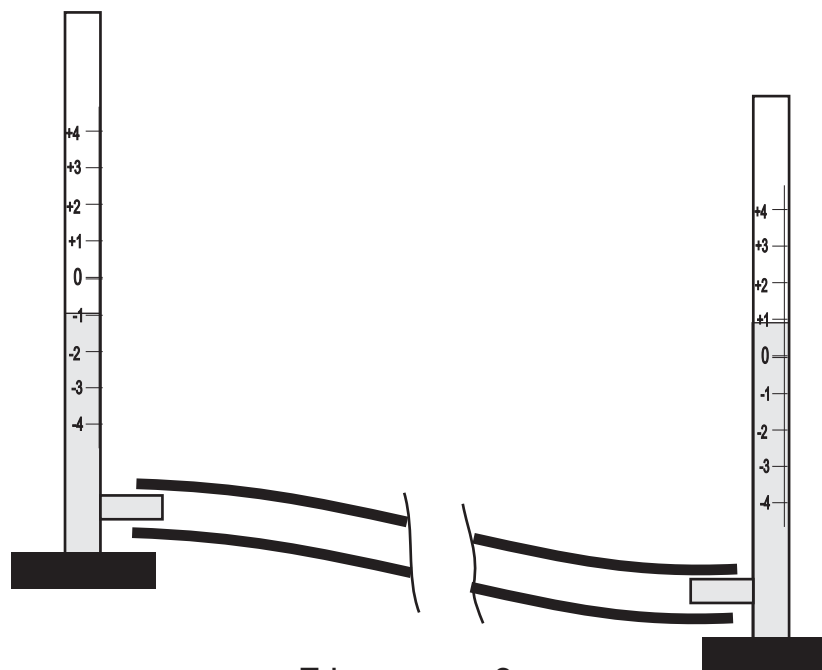

Figure 2
Carpenter Level Setup



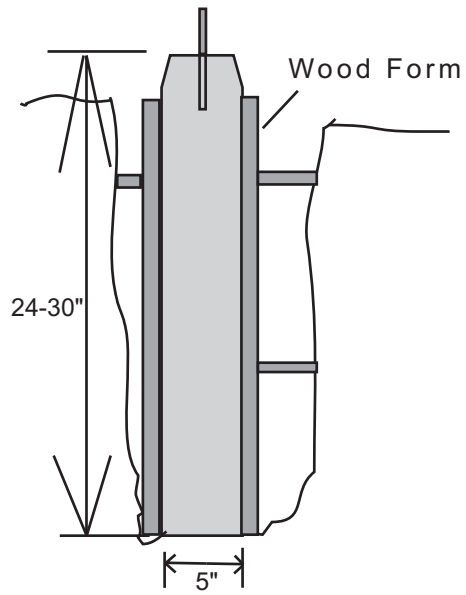

Figure 4
Ring Foundation Cross-section
(Poured Concrete)

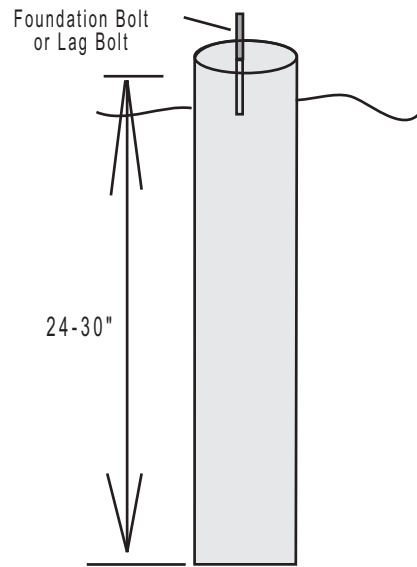

Figure 6
Wood Pier Foundation
(Post in Ground)

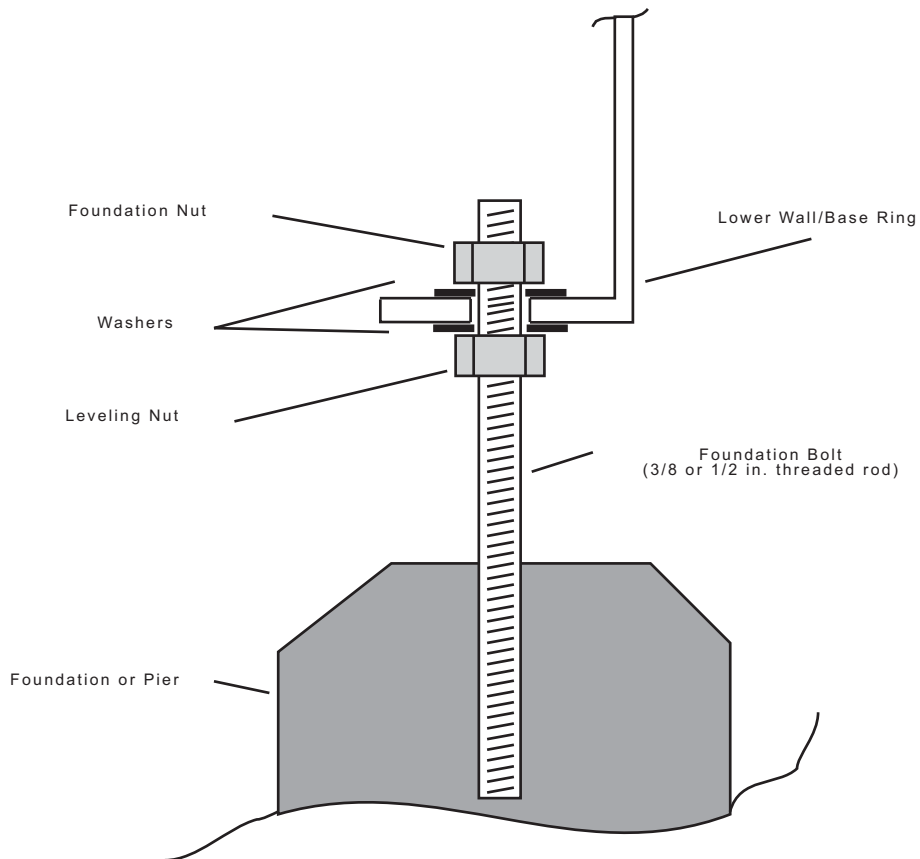
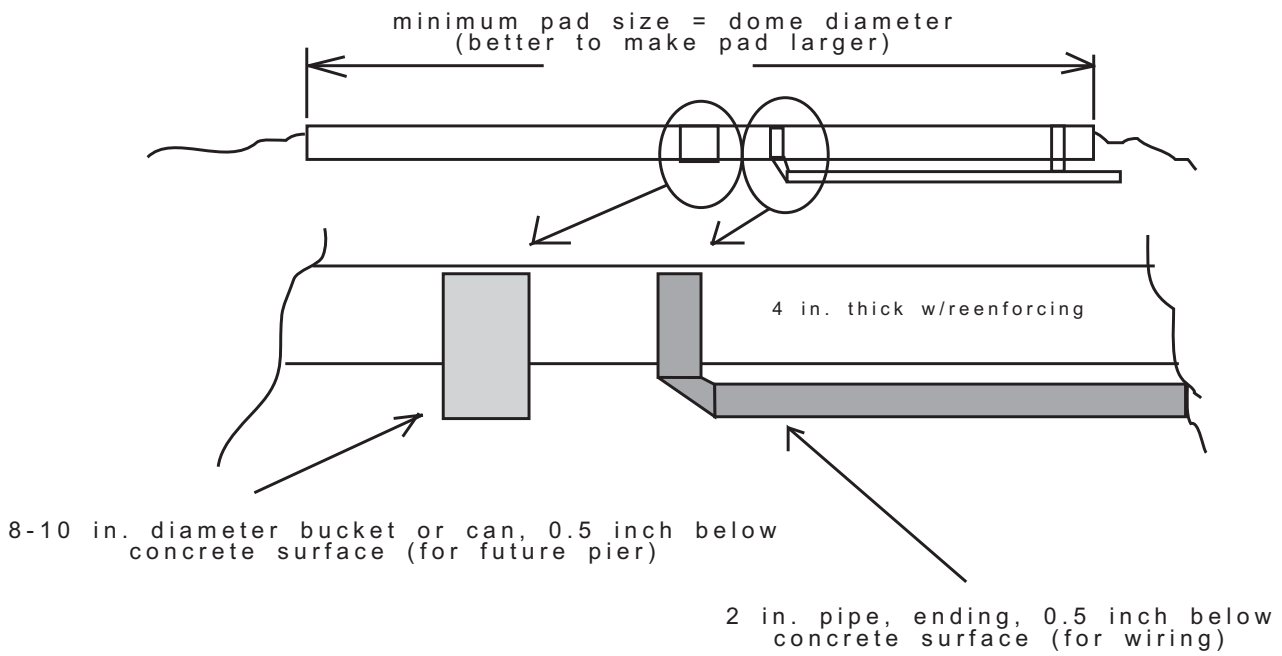
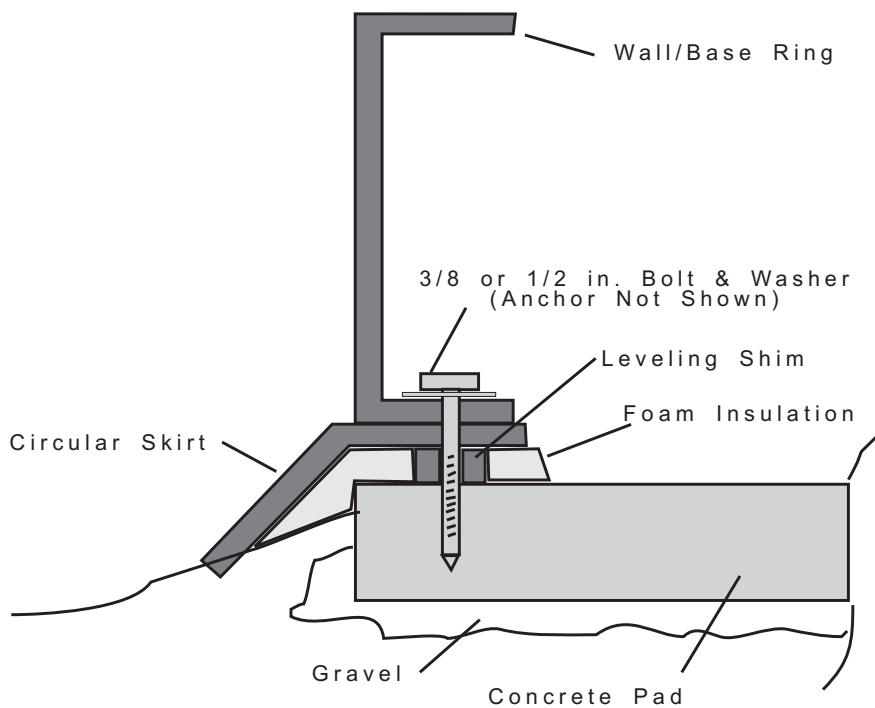

Figure 5
Foundation Bolts & Leveling



CONCRETE PAD DETAIL



FOUNDATION MOUNTING AND SKIRT DETAIL

Pad with Bolts & Shims Figure 7

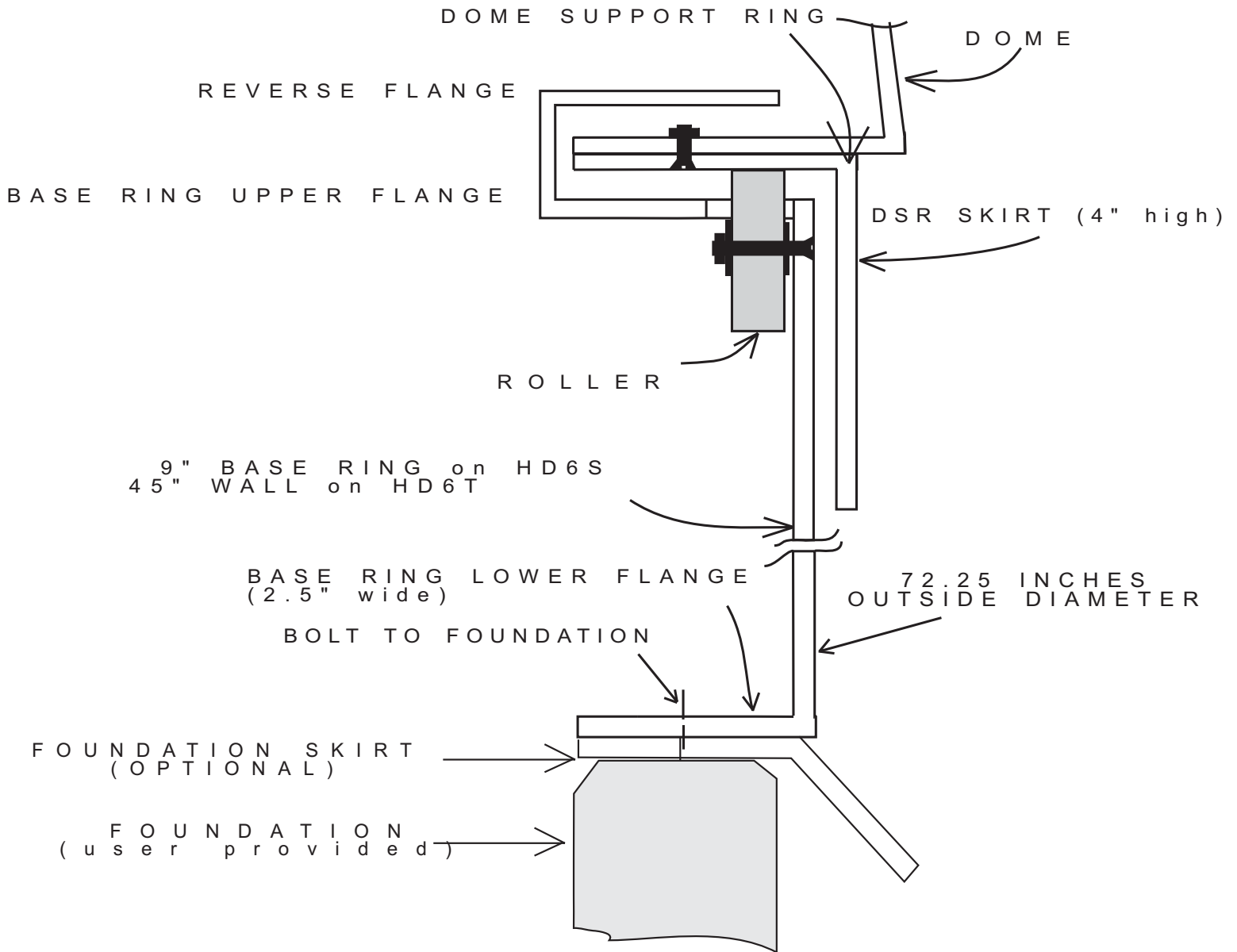

Hd6 Base Ring Structure Fig 9

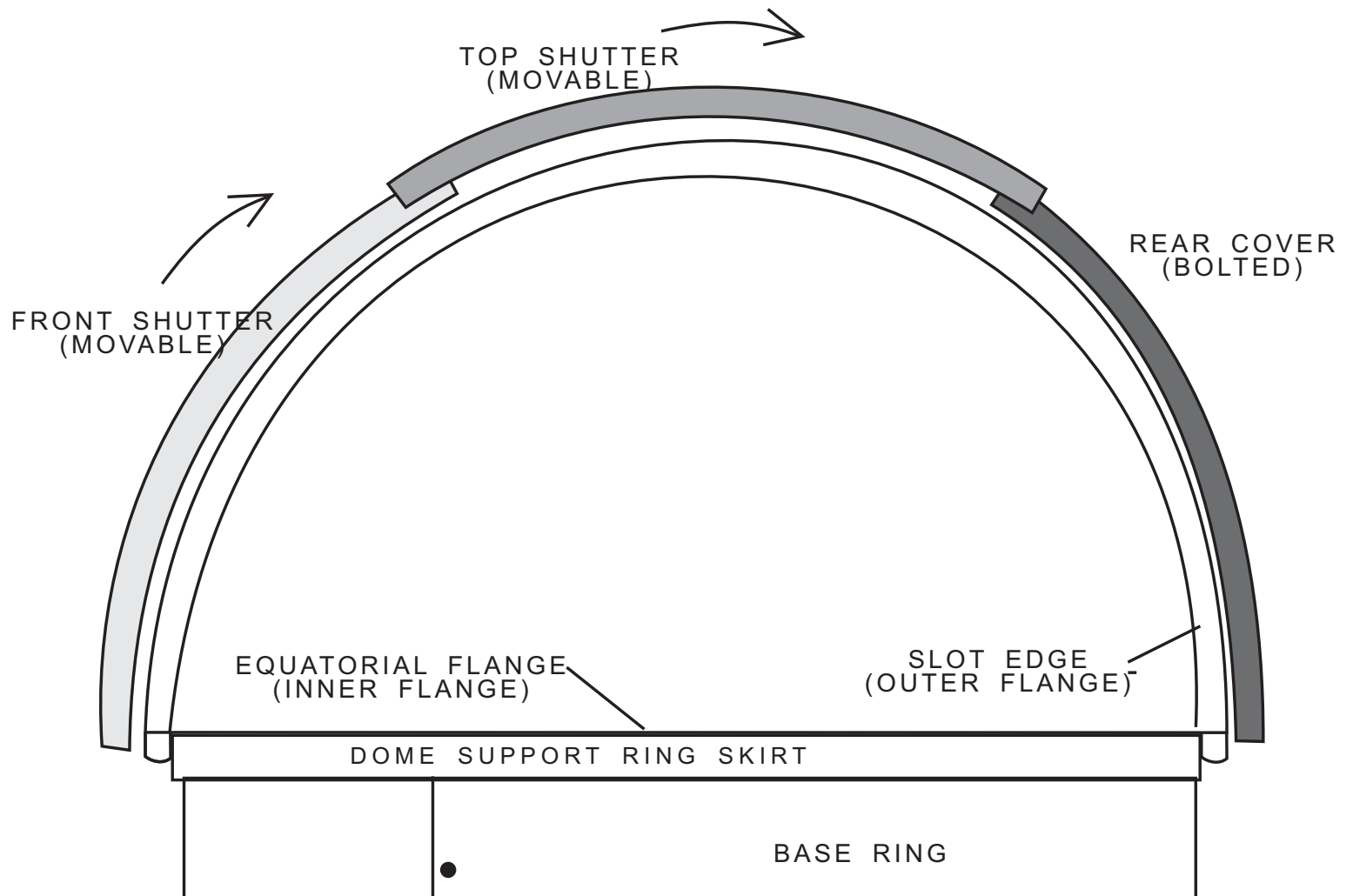

NOTES:

1. SHUTTERS & REAR COVER SHOWN REMOVED
2. 6'DOME HAS TWO HALVES INSTEAD OF FOUR QUADRANTS

FIGURE 10B

SIDE VIEW, HD6

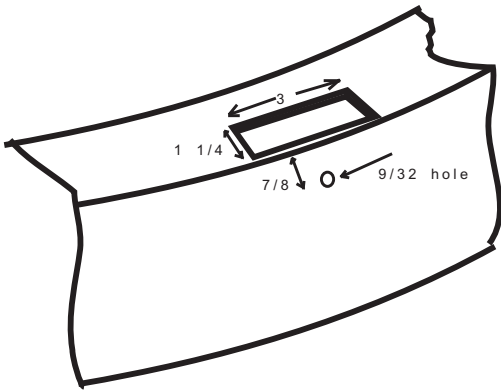

BASE RING - ROLLER HOLE

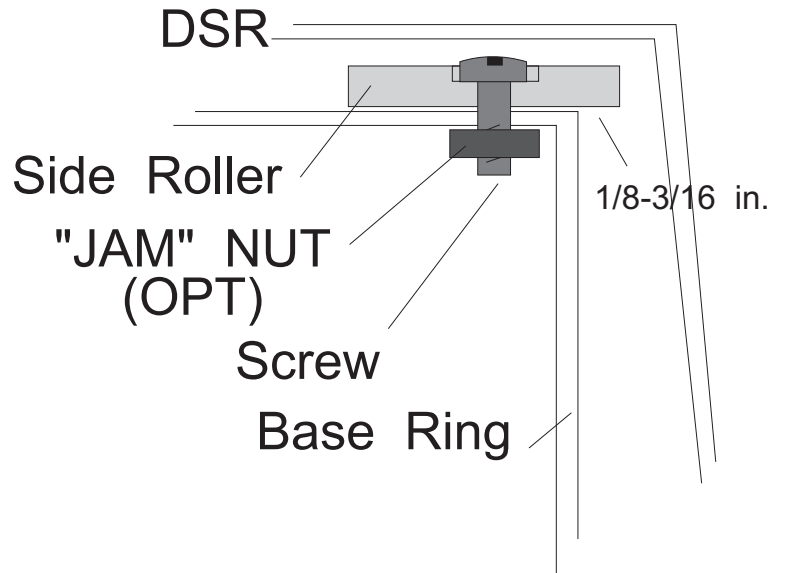
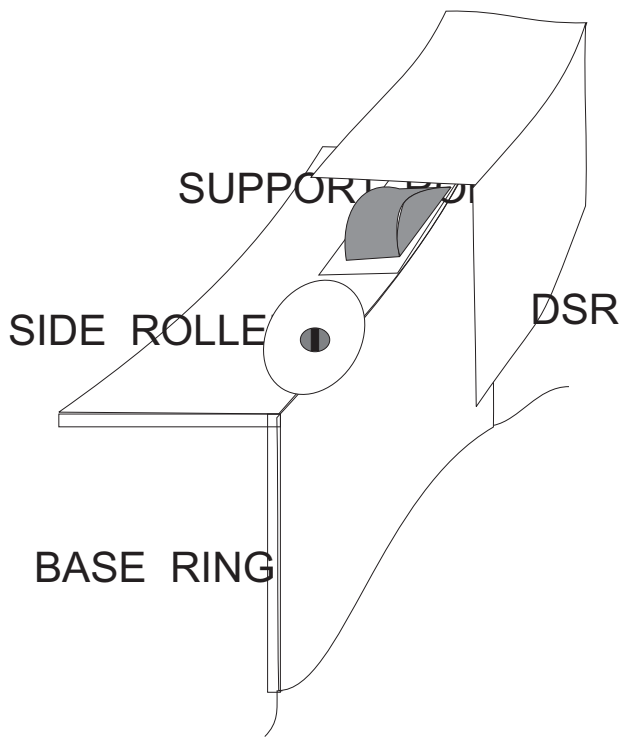
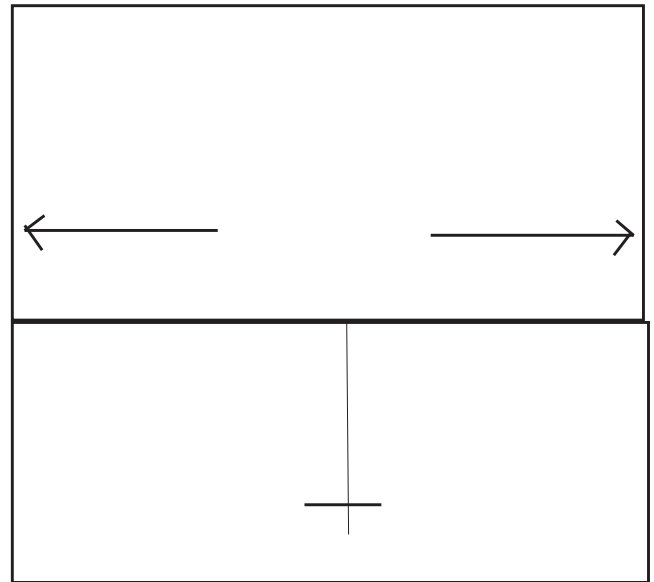

ROLLERS FIG 11

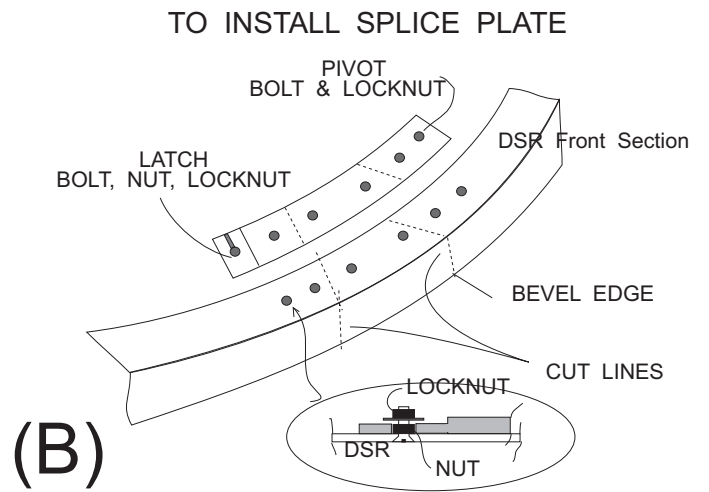
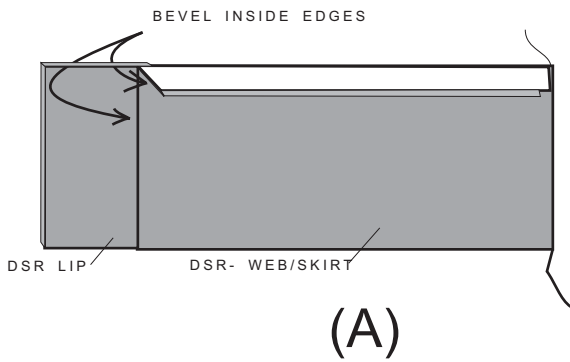

DSR - BEVELS
& SPLICE PLATE

FIG 12

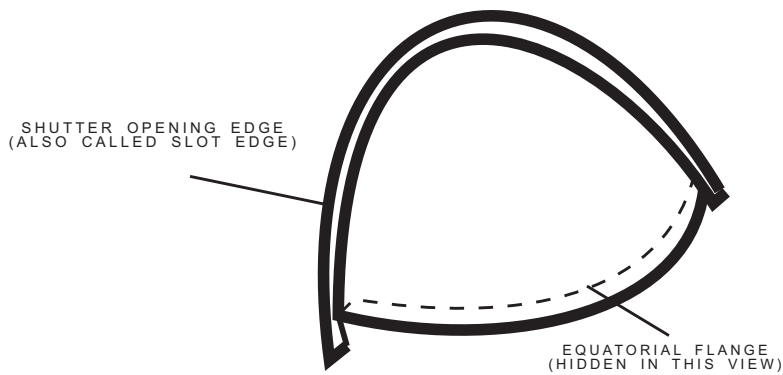
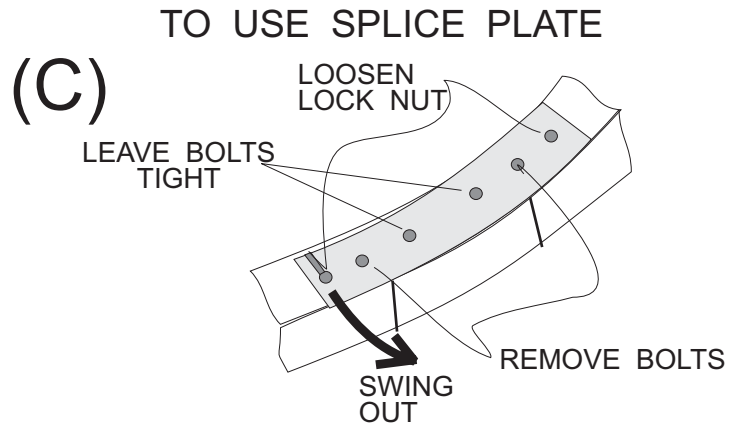

RIGHT DOME HALF - FLANGE NOMENCLATURE

FIG 13

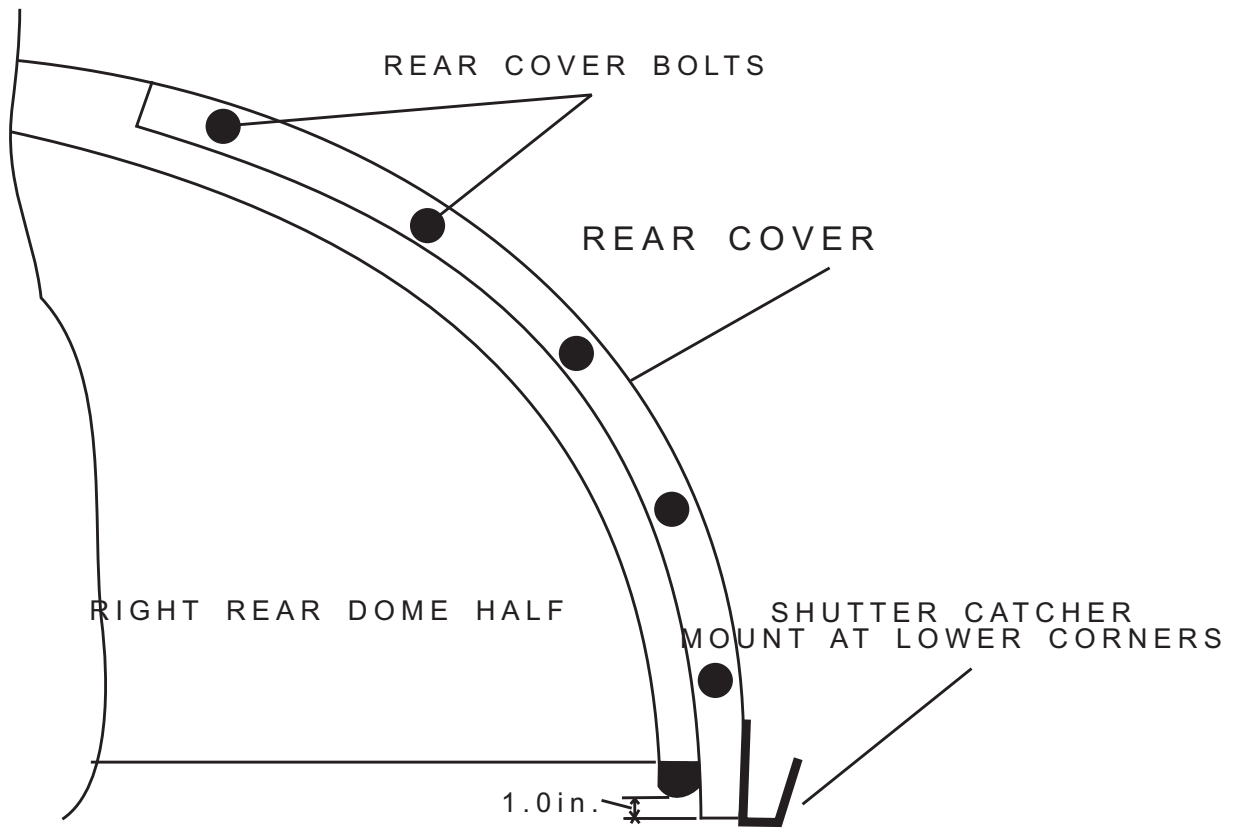

REAR COVER INSTALLATION
Figure 14

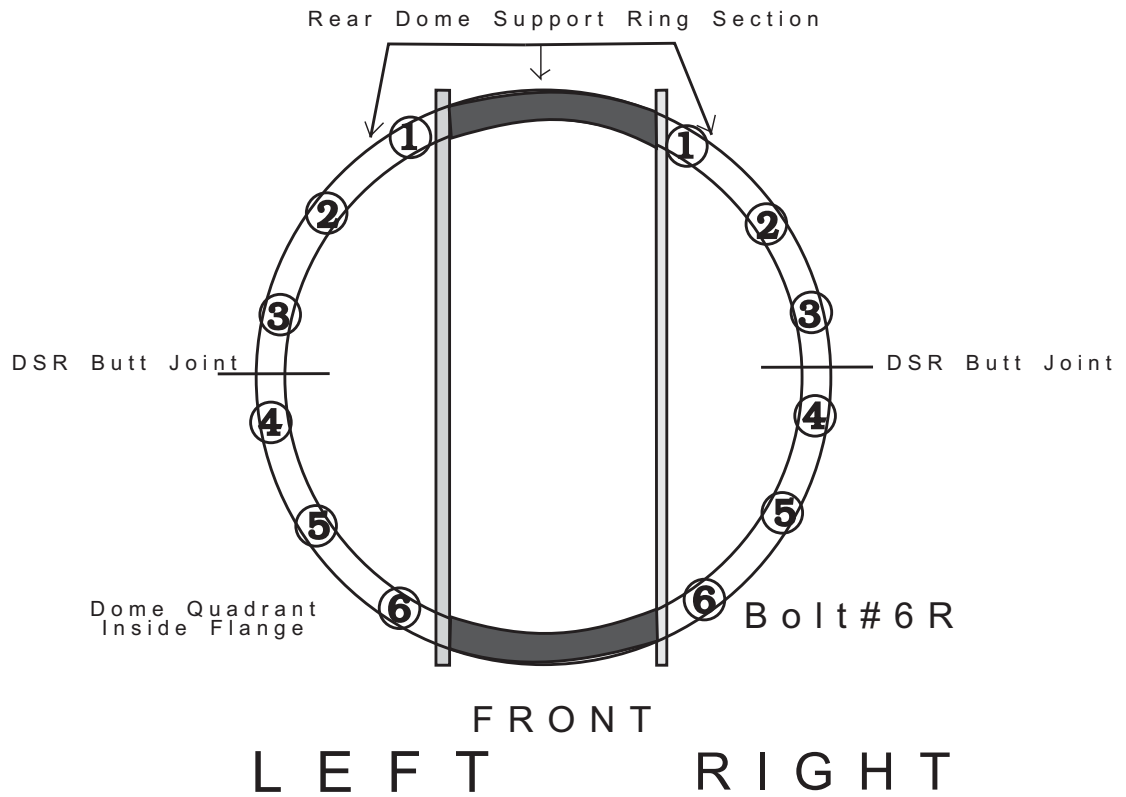

Dome Halves: Bolt Identification
Figure 15

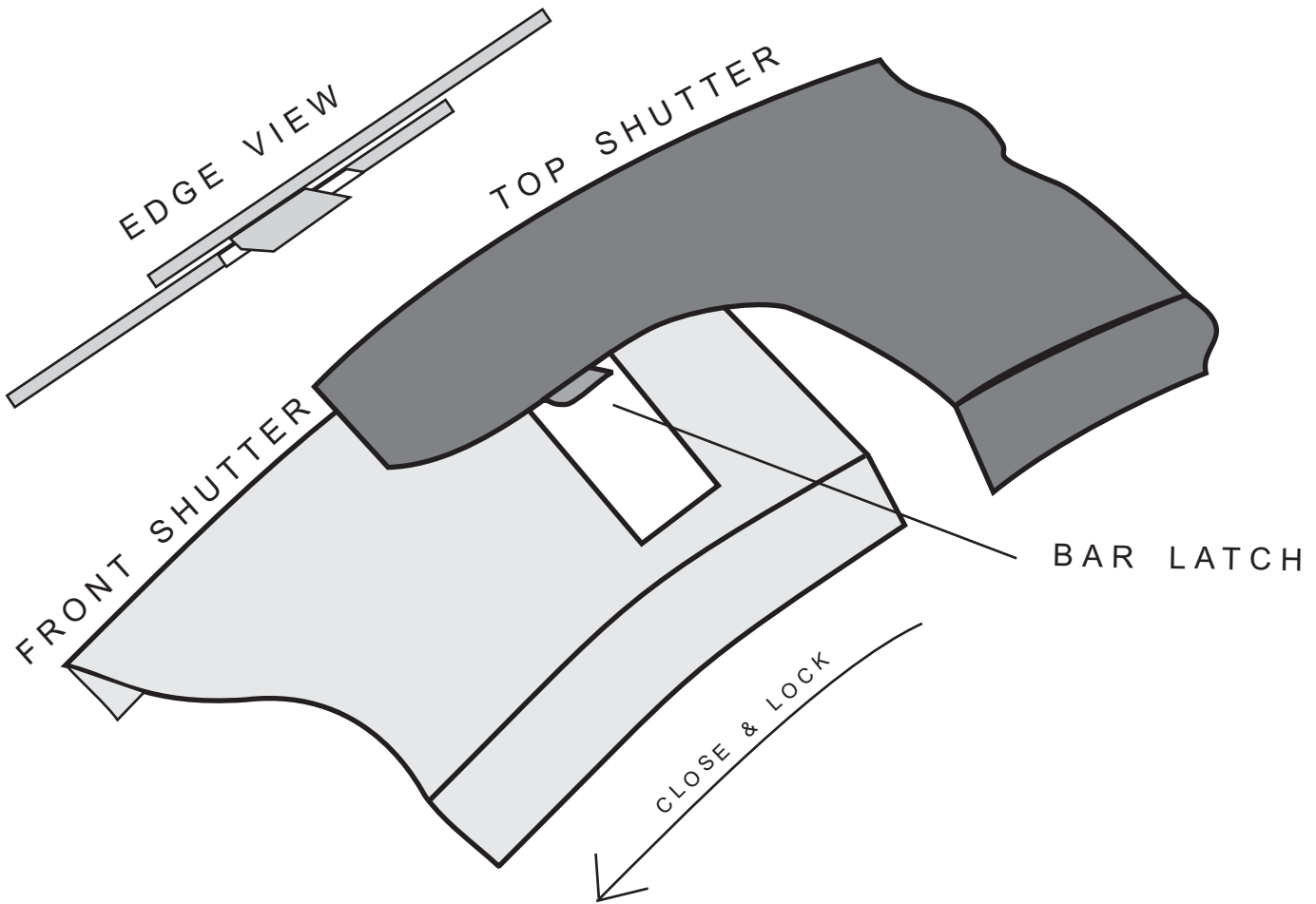

FRONT SHUTTER LATCH CUT-AWAY

(REAR COVER LATCH SIMILAR)

FIG 16

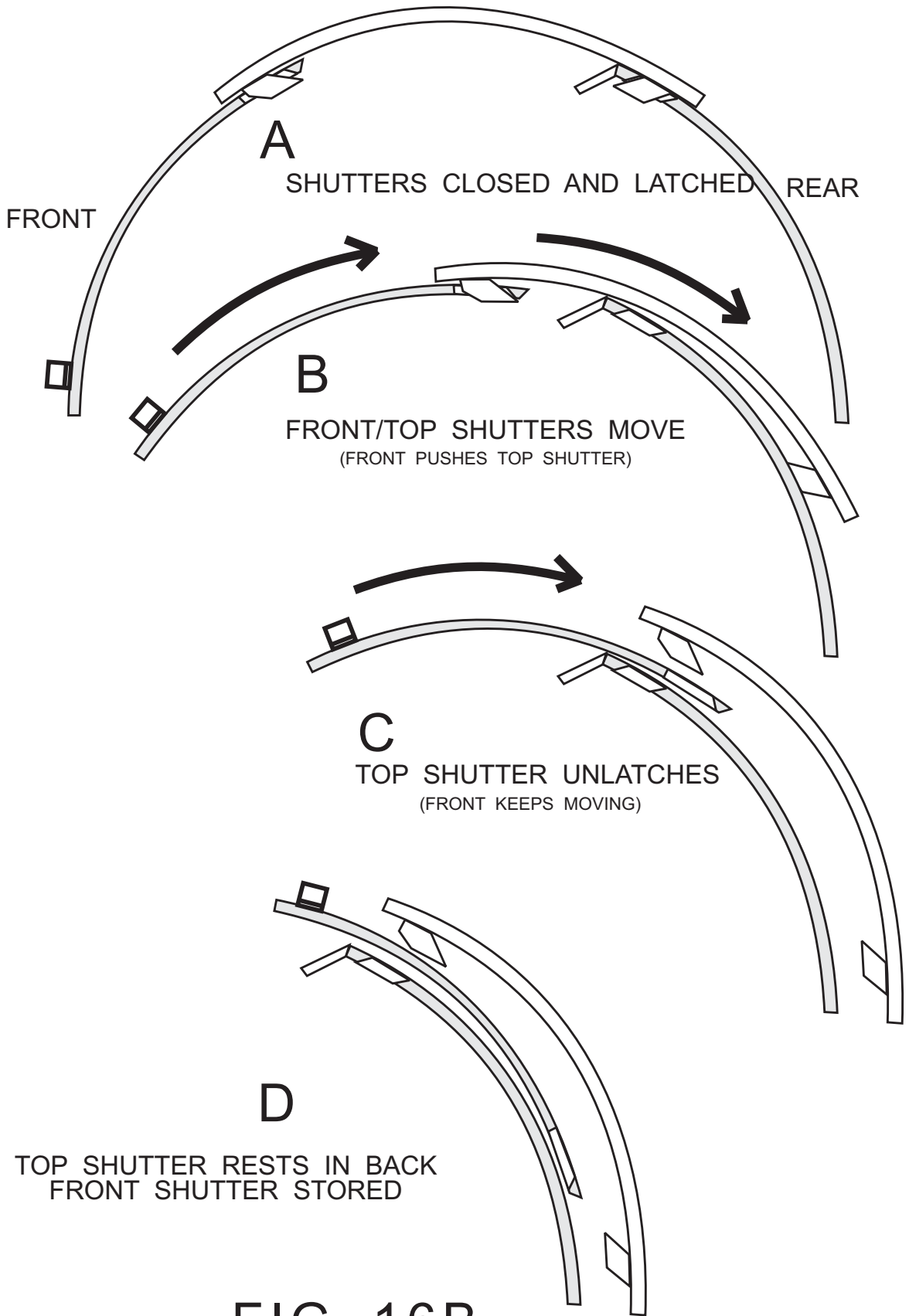

FIG 16B
SHUTTER OPERATION

NOT TO SCALE

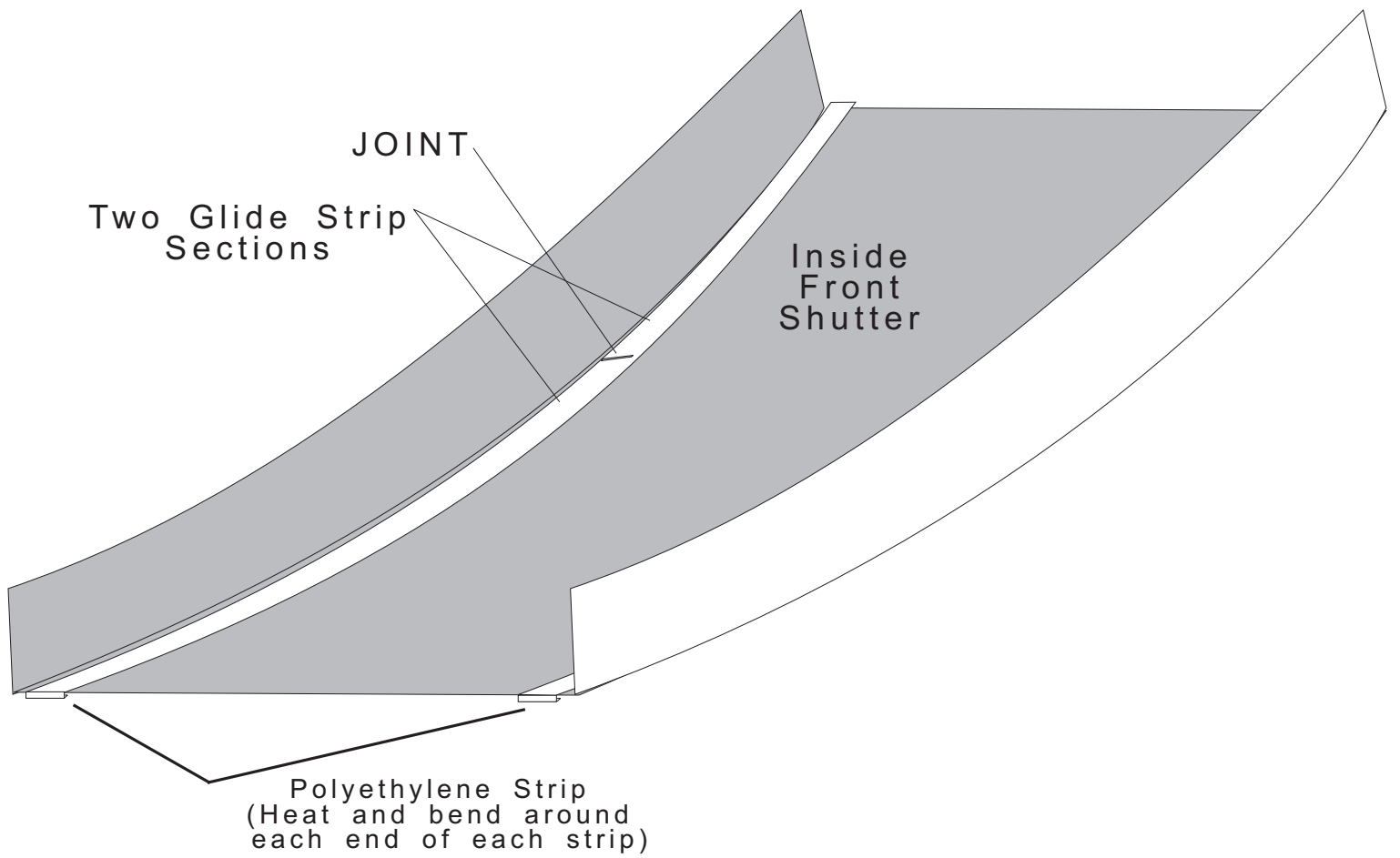
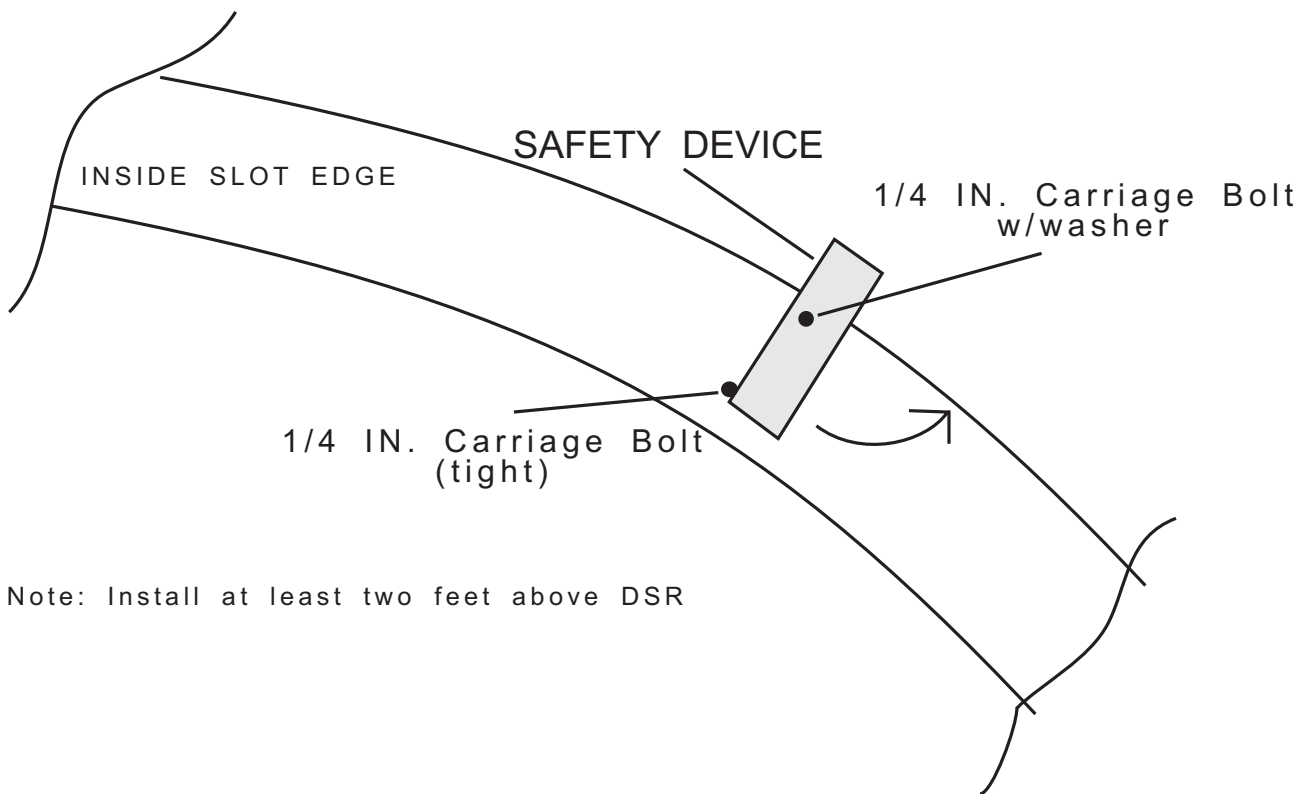

FIG 19 SHUTTER ANTIFRICTION STRIP



Note: Install at least two feet above DSR

SHUTTER SAFETY DEVICE
Figure 18

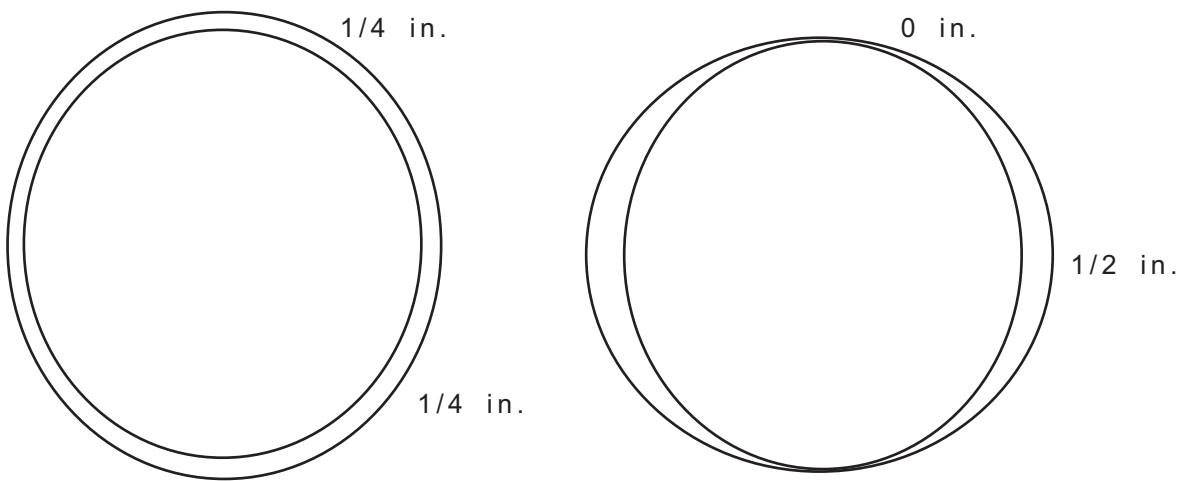
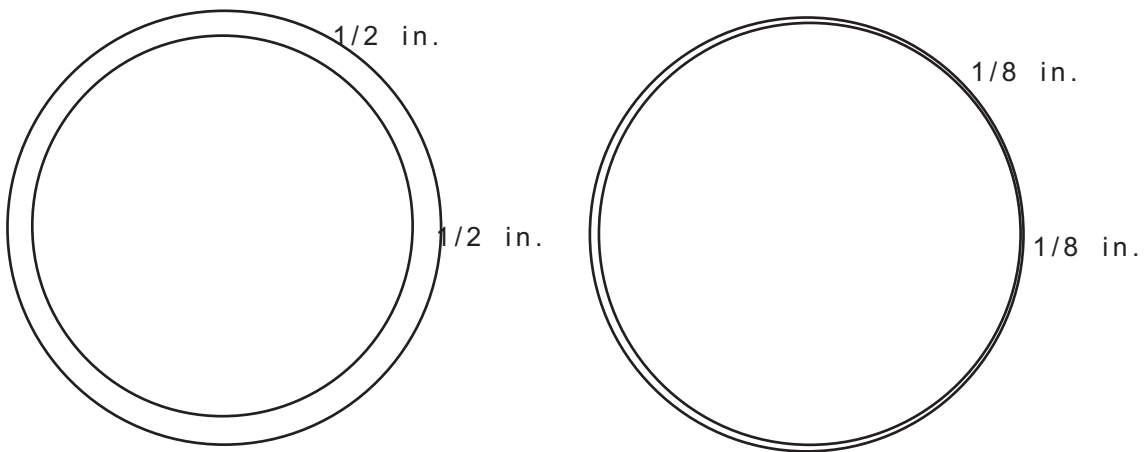
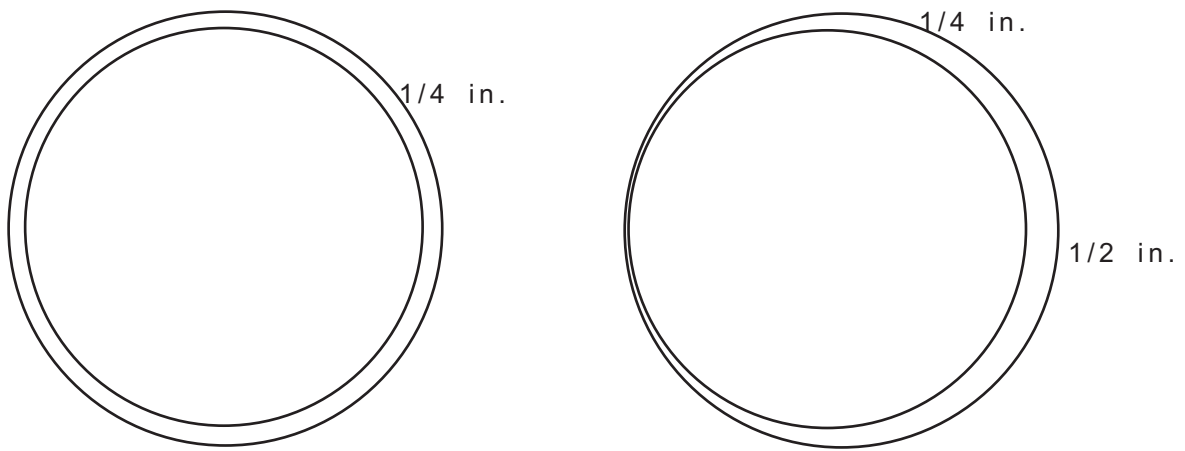
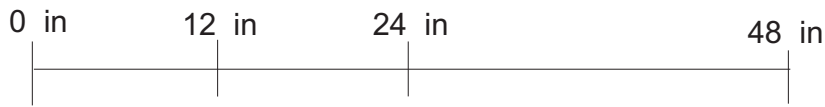
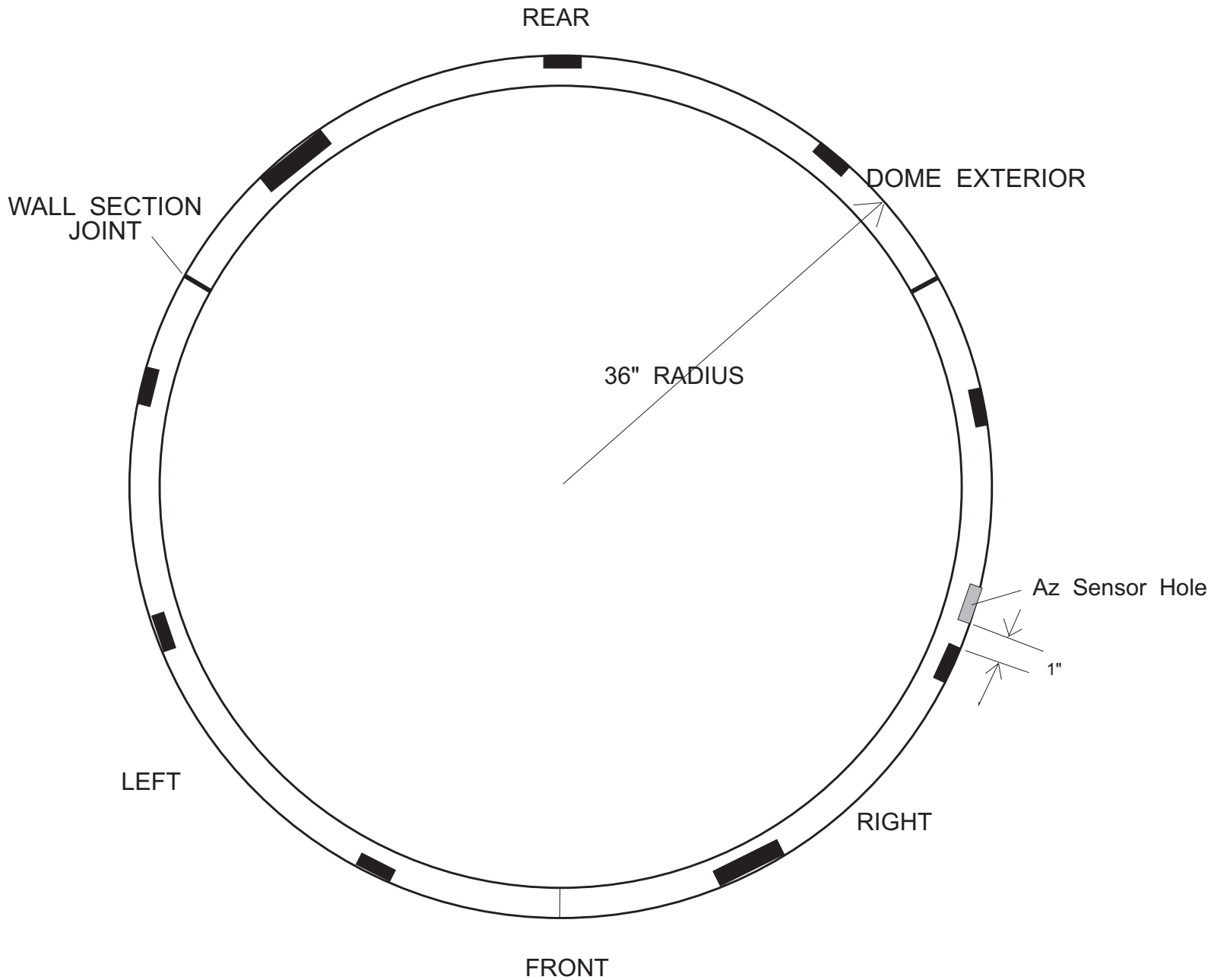

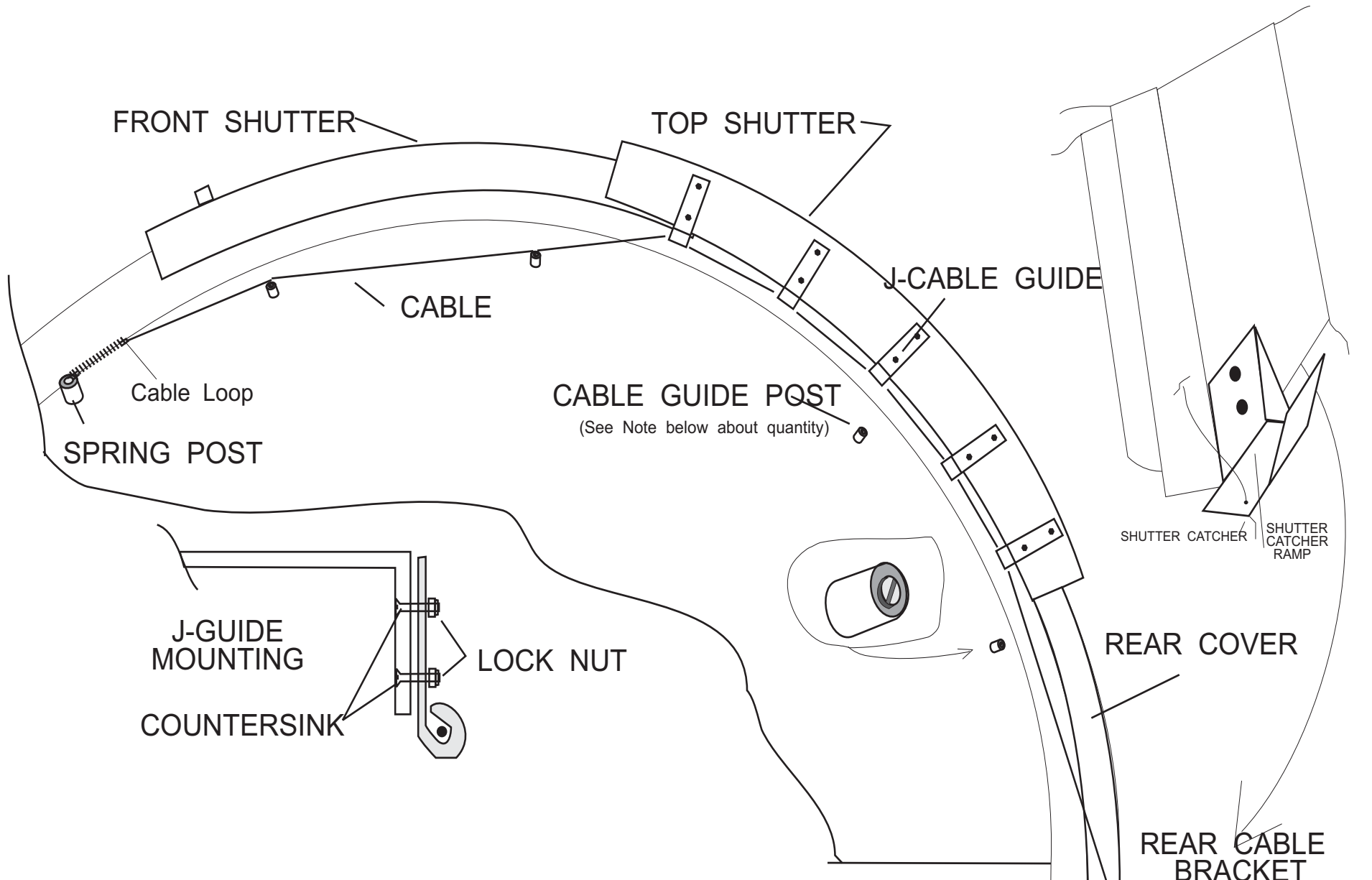

FIG 21 - ROTATION TESTS



-  ROLLER HOLE
-  ROLLER HOLE OR OPTIONAL DOME DRIVE

Hd6 BASE RING LAYOUT
FIGURE 23A



Generic SHUTTER RESTRAINT SYSTEM

FIG 24

Notes:

1. Drawing is generic-different domes use different numbers of parts
2. HD6 Uses four J-guides and four guide posts each side.
3. HD10/PD10 uses five J-guides and four guide posts each side
4. PD15 uses six J-guides and six guide posts each side
5. Space J-guides equally starting about 4" from the ends of the shutter

Note: Cable clamp and spring may be switched end for end. Use rear (Outward) hole

PD117
082101