

**TECHNICAL INNOVATIONS  
7851 CESSNA AVE  
GAITHERSBURG, MD 20879  
301-977-9000**

**Instructions  
Rectangular Skirt RS-6**

©2000 Technical Innovations

**Parts List**

Fiberglass Pieces (4)  
Carriage Bolts & hardware (2 each to join sections, plus 9 to join skirt to base ring)  
Caulk

**Introduction**

The RS provides a transition from the six-foot HOME-DOME observatory to a square building or to a gabled roof. These instructions cover several methods of installation of the rectangular skirt. The RS is shown in the attached drawing. The skirt is designed for use in several alternative ways. We urge that you read all the instructions to assure understanding of the methods of installation and use.

The RS forms a complete square 6 ft. 7 in. with a drip flange 1.5 in. high. The RS has a horizontal ring flange of about 3 in. radial width, with an ID of 6' 6.75 in., which is intended to fit beneath the lower base ring flange. The RS is composed of four sectors, with each sector having a lip that overlaps the adjacent sector. The short lips are caulked and bolted together with carriage bolts (1/4-20x3/4). Use a 5/16 in. drill for the bolt holes.

**Framing your structure**

In a typical installation, the dome base ring will sit on the horizontal flange of the skirt. You can choose whether to provide framing below this flange because the skirt is strong enough to support the HD6S weight. If you do provide framing, it must be 4 in. higher than your structure because the skirt has a slope.

Also typical, the drip flange of the skirt will fit over the upper edge of your structure. To make the skirt fit well, the outside dimension of your square structure should be 6 ft. 6.75 in. to allow for the thickness of the fiberglass material. You can get a better fit if you bevel the corners of your framing. This is because the underside of the fiberglass has a slightly curved surface in the corners.

## Installation

- 1. Normal Installation.** As noted above, a typical dome installation on a square building would provide for the bottom flange of the HOME-DOME base ring to be mounted on a supporting structure that is about 4 in. above the square "rim" or edge of the building. The RS horizontal flange is mounted beneath the base ring, so that the base ring foundation bolts hold the RS in place. This joint must be caulked with high quality silicon caulk. The RS then slopes out and downward to the "rim" of the building.

The RS drip flanges hang down the outside. The overlapped lips joining the sectors are trimmed to the desired length (use a sabre saw) and bolted together as described above. If feasible in the installation, we recommend rustproof screws through the drip flanges (and into the building, if possible) to help prevent high winds from lifting the skirt. You must provide these screws.

- 2. Skirt as support for dome.** It is also possible to use the skirt itself as the support for your HD-6S, rather than a separate support structure. To do this, your roof opening must be square. Construct an upright board (e.g. 2x6) on each side that is approximately 6 ft. 6.75 in. long, 2.5 in. high. Design the structure so that the upright boards can be adjusted to a close fit to the inside of the drip flanges as the base ring and skirt are assembled. This allows you to bolt the drip flange directly to your roof opening. Use rustproof screws (preferably stainless steel) several inches long. Thus, you will form a square support with a circular opening on which the dome base ring is bolted. Bolt the lips together as directed above, and caulk to prevent leaks. Use a sufficient number of screws into your roof edge to provide strength and stability.
- 3. No Drip Flange.** In some installations, some portion of the drip flange must be removed to allow the skirt to transition to an existing roof. In this case, use a sabre saw or other means to cut away the desired portion of the drip flange. Be sure to use eye and ear protection. Assemble the RS using bolts as described above, or using screws through the RS into the roof.
- 4. No Base Ring Flange.** In some installations, it may not be possible to mount the RS with its horizontal flange beneath a base or wall ring flange. This will be the case where the HOME-DOME cannot be raised four inches above the roof edge to be matched. In this case, some or all the RS horizontal ring flange may be removed, leaving a circular edge on the inside of the rectangular skirt. This edge would then be fitted against the outside surface of the base or wall ring.

To assure that the resulting fit of the skirt to the wall/base ring will be as good as possible, you need to measure and cut with care. It is best to use a section of base ring as a guide for marking the circle, but you **MUST** have the skirt at the proper angle to the base/wall ring surface or your measurement will be incorrect.

Once cut to the proper curve, the skirt can be joined to outside of the base or wall ring using simple angle brackets made of metal or plastic, preferably mounted on the underside of the skirt using screws, pop rivets, or other means. The joint can be sealed using high quality silicon caulk, bathtub edging or similar material, or by fiberglassing the joint (see an automotive or marine supply store for materials). Again, it is important to caulk and bolt the overlapping lips of the skirt sectors, and to screw down the outer edges of the skirt or drip flange to prevent wind damage.

**Rectangular Observatory Skirt**

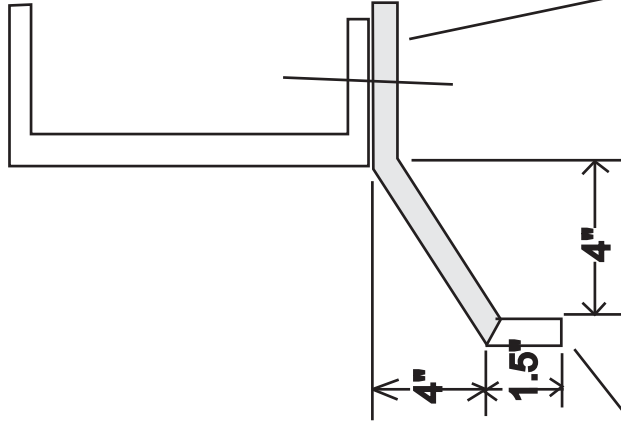
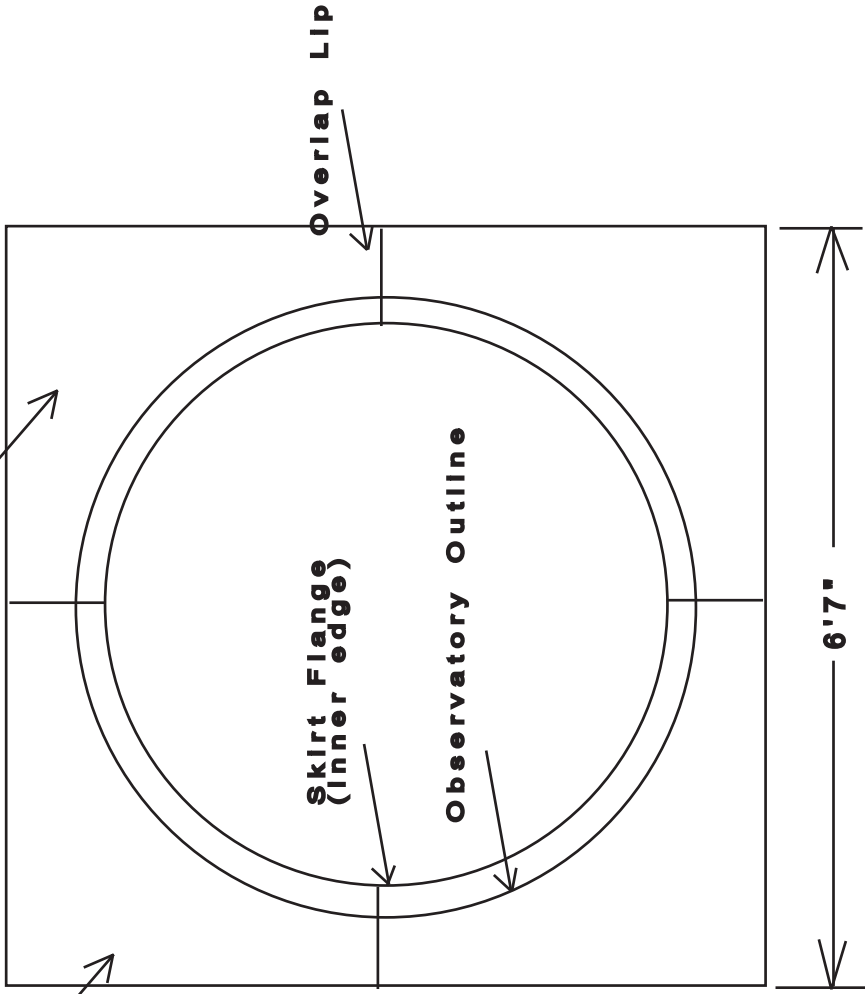

**Drip flange may be removed to fit skirt to roof line**

**Flange may be removed so skirt can be installed on outside of ring (use metal brackets, caulk)**

**Rectangular Observatory Skirt (NOT TO SCALE)**

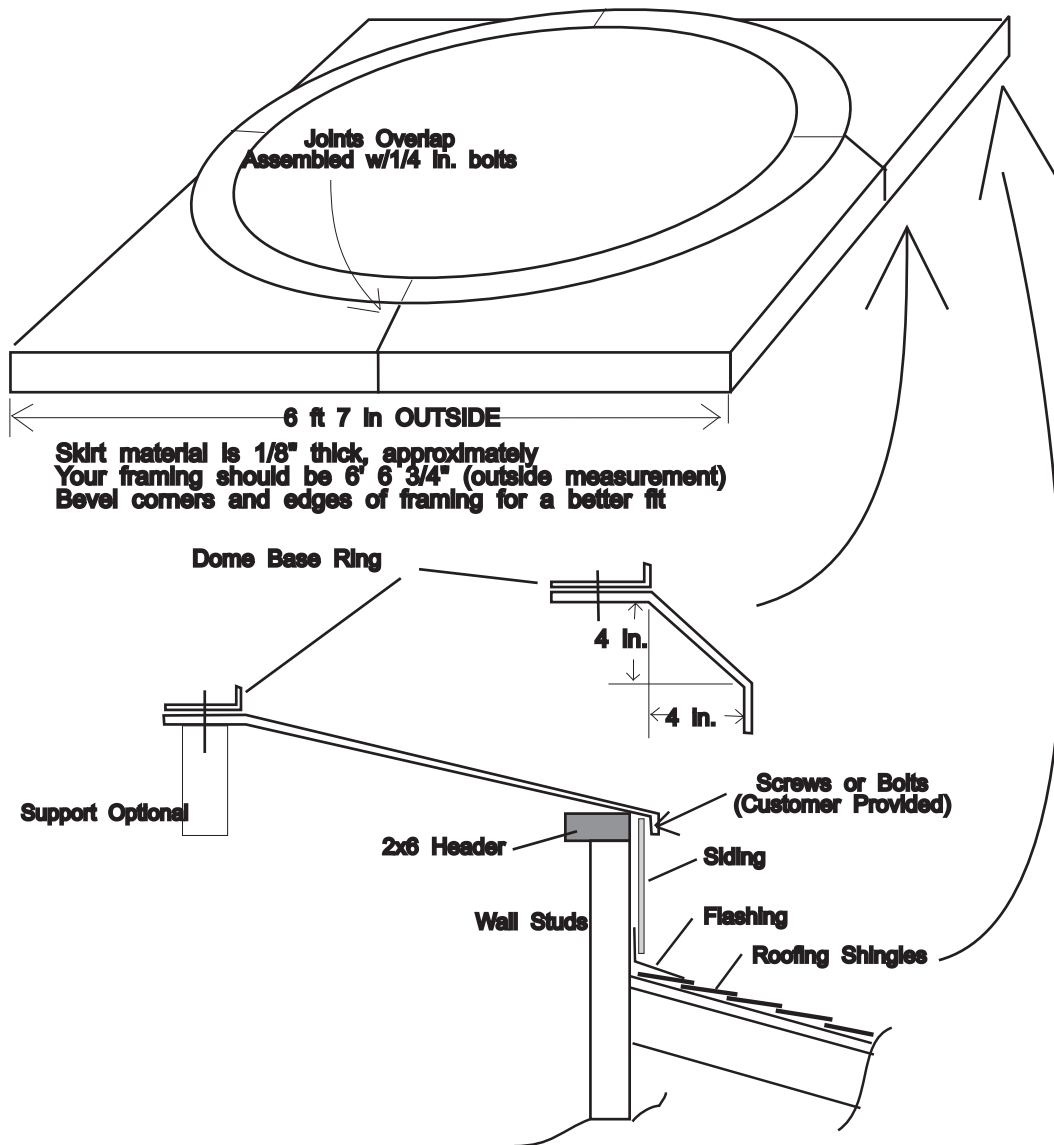

**Typical Installation**

# RECTANGULAR SKIRT RS6

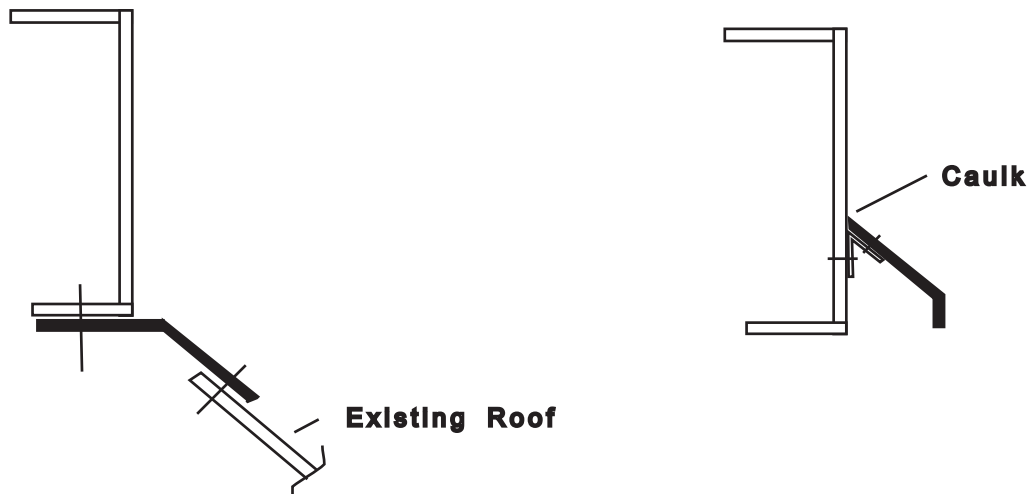
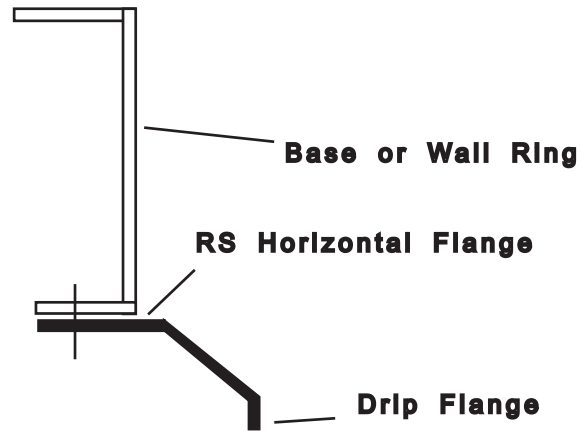

# Rectangular Skirt Installation Methods