

Technical Innovations
7851 CESSNA AVE
GAITHERSBURG, MD 20879
301-977-9000

Instructions
Rectangular Skirt RS-10

©2000 Technical Innovations

Parts List

Fiberglass Pieces (8)
Carriage Bolts & hardware (12)
Caulk

Introduction

The RS provides a transition from the ten foot HOME-DOME observatory to a square building or to a gabled roof. These instructions cover several methods of installation of the rectangular skirt. The RS is shown in the attached drawings. The skirt is designed for use in several alternative ways. We urge that you read all the instructions to assure understanding of the methods of installation and use.

The RS forms a complete square 10 ft 8 in. with a drip flange 1.5 in. high. The RS has a horizontal ring flange of about 3 in. radial width, with an ID of 113 in. The RS is provided in eight sectors. Each sector has a lip that overlaps the adjacent sector. The short lips (near the center of the sides of the square) are caulked and bolted together with a single carriage bolt (1/4-20x3/4), while the long lips at the corners of the square receive two bolts. Use a 5/16 in. drill for the bolt holes.

Framing your structure

In a typical installation, the dome base ring will sit on the 3 in. horizontal flange of the skirt. You will need framing below this flange to support the dome weight. This framing must be 4 in. higher than the top of your building, because the skirt has a downward slope.

Also typical, the drip flange of the skirt will fit over the upper edge of your structure. To make the skirt fit well, the outside dimension of your structure should be 10 ft. 7½ in. to allow for the thickness of the fiberglass material. You can get a better fit if you bevel the corners of your framing. This is because the underside of the fiberglass has a slightly curved surface in the corners.

Installation

1. **Normal Installation.** As noted above, typical installation on a square building should provide for the bottom flange of the HOME-DOME base ring to be 4 in. above the square "rim" or edge of the building. The RS horizontal flange is then mounted beneath the base ring, so that the base ring foundation bolts hold the RS in place. This joint must be caulked with high quality silicon caulk. Some installers put a rubber grommet between the bottom of the base ring flange and the top of the skirt flange.

The RS then slopes out and downward to the "rim" of the building. The RS drip flanges hang down the outside and we recommend that this drip flange be fastened to the upper edge of your structure with rustproof screws. (You must provide these screws.) The overlapped lips joining the sectors of the skirt are bolted together with the stainless steel bolts we include in your hardware set, as described above.

2. **No Drip Flange.** In some installations, some portion of the drip flange must be removed to allow the skirt to transition to an existing roof. In this case, use a sabre saw or other means to cut away the desired portion of the drip flange. Be sure to use eye and ear protection. Assemble the RS using bolts as described above, or using screws through the RS drip flange into the roof where feasible.
3. **No Base Ring Flange.** In some installations, it may not be possible to mount the RS with its horizontal flange beneath a base or wall ring flange. This will be the case where the HOME-DOME cannot be raised four inches above the roof edge to be matched. In this case, some or all the RS horizontal ring flange may be removed, leaving a circular edge on the inside of the rectangular skirt. This edge would then be fitted against the outside surface of the base or wall ring.

To assure that the skirt fits to the wall/base ring as well as possible, you need to measure and cut your support structure with care. It is best to use a section of base ring as a guide for marking the circle, but you **MUST** have the skirt at the proper angle to the base/wall ring surface or your measurement will be incorrect.

Once cut to the proper curve, the skirt can be joined to outside of the base or wall ring using simple angle brackets made of metal or plastic, preferably mounted on the underside of the skirt using screws, pop rivets, or other means. The joint can be sealed using high quality silicon caulk, bathtub edging or similar material, or by fiberglassing the joint (see an automotive or marine supply store for materials). Again, it is important to caulk and bolt the overlapping lips of the skirt sectors, and to screw down the outer edges of the skirt or drip flange to prevent wind damage.

SUGGESTED INSTALLATION CONCEPT

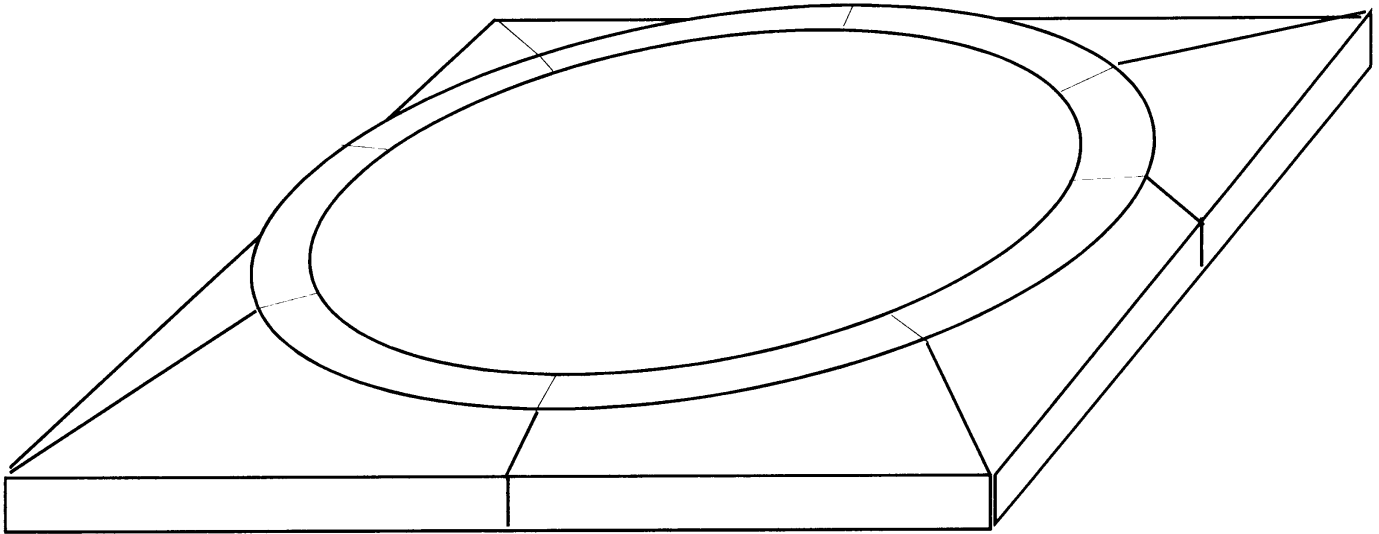

Each side 10'8" to outside

Skirt material is 1/8" thick approximately
Your framing should be 10'7.5" (outside measurement)
Bevel corners and edges of framing for a better fit.

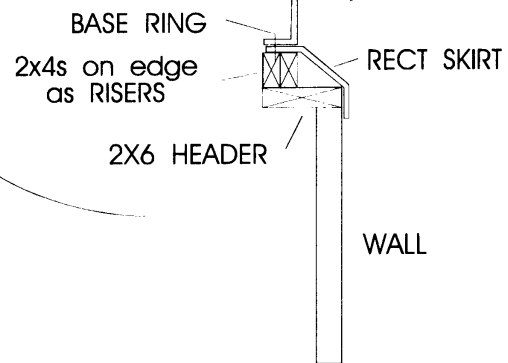
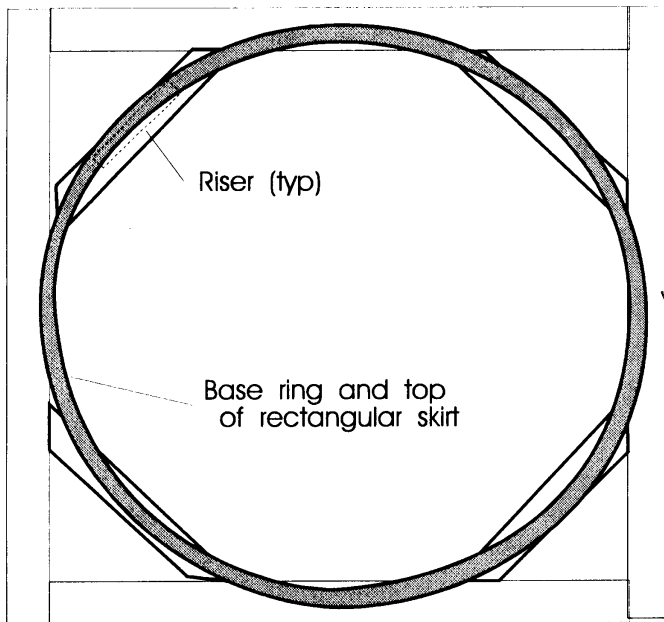
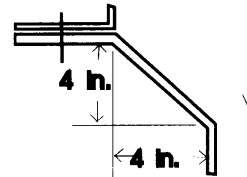

Note: If your risers extend outside the 119" base ring diameter you may need to plane or cut them to accommodate the downslope of the rectangular skirt.

STRUCTURAL FRAME SUPPORTS
SKIRT, BASE RING, & DOME

RECTANGULAR SKIRT, RS-10

frpparts.rs2C
040101